

**EN** Installation and operating instructions  
Last updated: 09.2022

# Control unit for dock levellers RS 301



## Table of contents

<b>1.</b>	<b>Safety information.....</b>	<b>3</b>
1.1	Correct use.....	3
1.2	Target groups .....	3
1.3	General safety advice.....	3
<b>2.</b>	<b>Product information .....</b>	<b>4</b>
2.1	Description.....	4
2.2	Versions .....	4
2.3	Function tables .....	4
2.4	Housing overview .....	5
2.5	Circuit board overview .....	6
2.6	Technical data RS 301.....	6
<b>3.</b>	<b>Installation.....</b>	<b>7</b>
3.1	Safety instructions for installation .....	7
3.2	Mains connection .....	7
3.3	24 V DC for external devices .....	8
3.4	Connection of emergency stop device .....	8
3.5	Connection of valves .....	9
3.6	Connection of pushbuttons .....	9
3.7	Connection of signal traffic lights .....	9
3.8	Connection of loading bridge limit switch .....	10
3.9	Connection of approach sensor.....	10
3.10	Wheel block connection .....	11
3.11	Connection of the tubular motor / fan (shelter function).....	11
3.12	Connection of signal horn / loading light / Fan (shelter function).....	12
3.13	Connection to the gate controller .....	13
3.14	Connection of free input .....	14
<b>4.</b>	<b>Functional description .....</b>	<b>15</b>
4.1	Operation of the loading bridge .....	15
4.2	Automatic Return (AR).....	15
4.3	Start-up interlocking .....	16
4.4	Rotating field test / Phase failure detection .....	16
4.5	Current monitoring .....	16
4.6	Time and current measurement.....	17
<b>5.</b>	<b>Programming.....</b>	<b>19</b>
5.1	Overview of the LCD monitor .....	19
5.2	LCD monitor operating modes .....	19
<b>6.</b>	<b>Navigator .....</b>	<b>20</b>
<b>7.</b>	<b>Functional overviews .....</b>	<b>22</b>
7.1	Automatic mode .....	22
7.2	Input operating mode.....	23
7.3	Function tables for valve actuation .....	33
7.4	Diagnostics operating mode.....	36
7.5	Fault display on the LCD monitor.....	37
7.6	Fault display via LED 1 .....	37
<b>8.</b>	<b>Care .....</b>	<b>38</b>
<b>9.</b>	<b>Servicing .....</b>	<b>38</b>
9.1	Maintenance.....	38
9.2	Testing .....	38
<b>10.</b>	<b>Disassembly .....</b>	<b>38</b>
<b>11.</b>	<b>Disposal .....</b>	<b>38</b>
<b>12.</b>	<b>Declaration of incorporation.....</b>	<b>39</b>
<b>13.</b>	<b>Annex .....</b>	<b>40</b>
13.1	Overview of the connections .....	40

## About this document

- Original operating manual.
- Part of the product.
- Reading and subsequent storage mandatory.
- Protected by copyright.
- No part of this manual may be reproduced without our prior consent.
- Subject to changes which are in the interest of technical improvements.
- All dimensions in millimetres.
- Figures are not to scale.

### Safety instructions

#### **WARNING!**

Safety information regarding a danger that can lead to death or serious injuries.



#### **CAUTION!**

Safety information regarding a danger that can lead to minor or moderate injuries.

#### **ATTENTION!**

Safety information regarding a danger that can lead to damage or destruction of the product.

### Meaning of symbols

- Action prompt
- ✓ Check
- List, itemisation
- Reference to other parts of this document
-  Reference to separate documents that must be observed
-  Factory settings

# 1. Safety information

## **WARNING!**

### **Risk of death due to a failure to observe the operating manual!**

This manual contains important information for handling the product safely. Particular reference is made to possible dangers.

- Read this manual through carefully.
- Follow the safety instructions in this manual.
- Store the manual in an accessible location.

## 1.1 Correct use

The RS 301 control unit is intended exclusively for controlling dock levellers with a hinged lip or feed lip. It is possible to control dock levellers with 1, 2 or 3 valves.

Use is only permissible:

- In technically faultless condition.
- Following correct installation.
- In compliance with the data in the technical specifications.

→ "2.6 Technical data RS 301"

Any other use is deemed to be improper use.

## 1.2 Target groups

### 1.2.1 Operator

The operator is responsible for the building in which the product is used. The operator has the following tasks:

- Knowledge and safekeeping of the instruction manual.
- Instruct all persons who use the system.
- Ensure that the system is inspected and maintained regularly by qualified specialist personnel in accordance with the manufacturer's instructions.
- Make sure that inspection and maintenance are documented in the inspection logbook.
- Safe and proper keeping of the inspection logbook.

### 1.2.2 Specialist personnel

Qualified specialist personnel are responsible for assembly, commissioning, maintenance, repair, disassembly and disposal.

Requirements applicable to qualified specialist personnel:

- Knowledge of the general and specific safety and accident-prevention regulations.
- Knowledge of the relevant electrical regulations.
- Training in the use and care of appropriate safety equipment.
- Ensure knowledge of the relevant standards.

Electrical work by qualified electricians exclusively, in accordance with DIN VDE 0100.

Requirements applicable to qualified electricians:

- Knowledge of the basics of electrical engineering.
- Knowledge of national regulations and standards.
- Knowledge of the relevant safety regulations.
- Knowledge of this operating manual.

### 1.2.3 Users

Instructed users operate and care for the product.

Requirements applicable to instructed users:

- Users are instructed in relation to their work by the operator.
- Users must have been instructed on how to use the product safely.
- Knowledge of this operating manual.

Special requirements apply to the following users:

- Children aged 8 and above.
- Persons with reduced physical, sensory or mental capabilities.
- Persons with a lack of experience and knowledge.

These users are only authorised to operate the product.

Special requirements:

- The users must be supervised.
- Users must have been instructed on how to use the product safely.
- The users must understand the dangers involved in handling the product.
- Children are not allowed to play with the product.

## 1.3 General safety advice

Persons or objects must never be moved with the aid of the system.

In the following cases, the manufacturer accepts no liability for damages. The guarantee on the product and accessory parts is voided with:

- A failure to observe these operating instructions.
- Misuse and improper handling.
- The assignment of unqualified personnel.
- Modifications or changes to the product.
- The use of spare parts that have not been produced or approved by the manufacturer.

The product is manufactured according to the directives and standards mentioned in the Declaration of Incorporation. The product has left the factory in perfect condition with regard to safety.

Batteries, accumulators, fuses and bulbs are excluded from warranty.

**Further safety information can be found in the relevant respective sections of the document.**

→ "3.1 Safety instructions for installation"

## 2. Product information

### 2.1 Description

The RS 301 control unit can be used on a dock leveller with hinged lip or feed lip, hydraulic power unit and up to 3 solenoid valves. The control unit is installed in the Marantec standard housing and generally has an integrated main switch. The functions FEED or HINGED LIP can be selected via the FACTORY MODE parameter.

### 2.2 Versions

#### Variant of the circuit board and housing

Variant with load contactor for actuating a door seal 400V/3~. Installation in the Marantec combination housing.

#### Command device variants

Feed lip version (FACTORY MODE 1)

Controller RS 301 with 3 direction buttons (standard)

- RAISE button
- LIP BACK button
- LIP FORWARDS button
- AUTO-RETURN button

Controller RS 301 with 2 direction buttons

- RAISE / LIP BACK. button
- LIP FORWARDS button
- AUTO-RETURN button

Controller RS 301 with 4 direction buttons

- RAISE button
- LIP BACK button
- LIP FORWARDS button
- LOWER button
- AUTO-RETURN button

Hinged lip version (FACTORY MODE 2)

RS 301 control unit with 1 direction buttons

- LIFT button
- AUTO RETURN button

#### Options

- LCD monitor with plain text display
- Housing with green/red indicator lamps
- Housing with emergency stop
- Housing with selector switch for door sealing

The operating instructions describe the connection options and variants of the RS 301 controller with the standard software from software version 1.0.

### 2.3 Function tables

Each loading bridge can be assigned to a function table. This overview of valve control distinguishes between 1, 2 or 3 valves on the RS 301, depending on the valve mode and/or factory mode. The overview provides a detailed view of which valves are switched when and by what. In this way it is possible to decide whether the RS 301 can be used directly or if a special solution is required. Customer-specific solutions can also be retrospectively added if necessary.

Overview of existing and pre-programmed function tables:

→ "7.3 Function tables for valve actuation"

## 2.4 Housing overview

### Version with 2 direction buttons

2.4 / 1

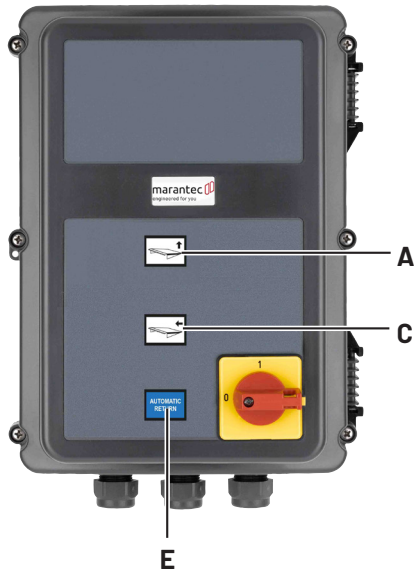

### Version with 4 direction buttons

2.4 / 3

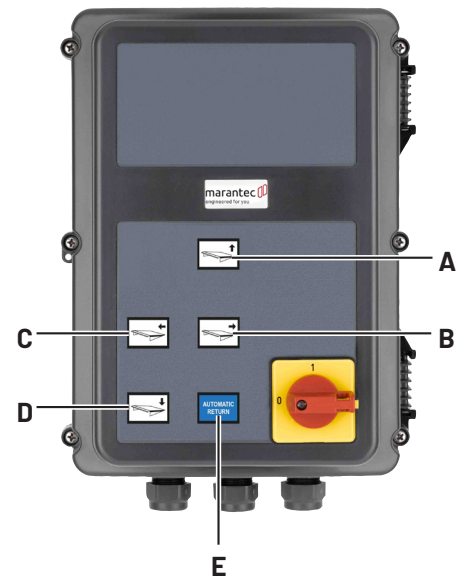

### Version with 3 direction buttons (Standard)

2.4 / 2

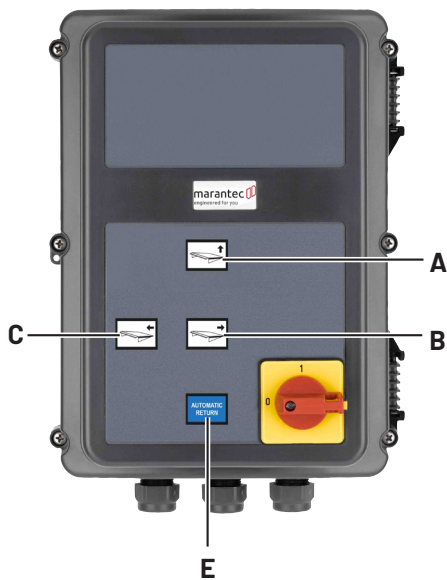

### Version with 1 direction button

2.4 / 4

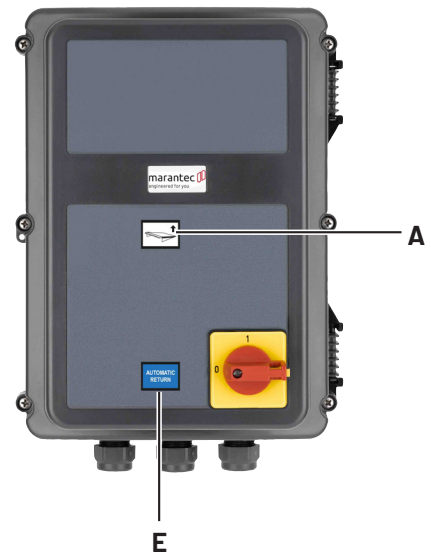

#### Legend:

- A RAISE button
- B LIP BACK button
- C LIP FORWARDS button
- E AUTO-RETURN button

#### Legend:

- A RAISE button
- B LIP BACK button
- C LIP FORWARDS button
- D LOWER button
- E AUTO-RETURN button

## 2.5 Circuit board overview

### 2.5 / 1

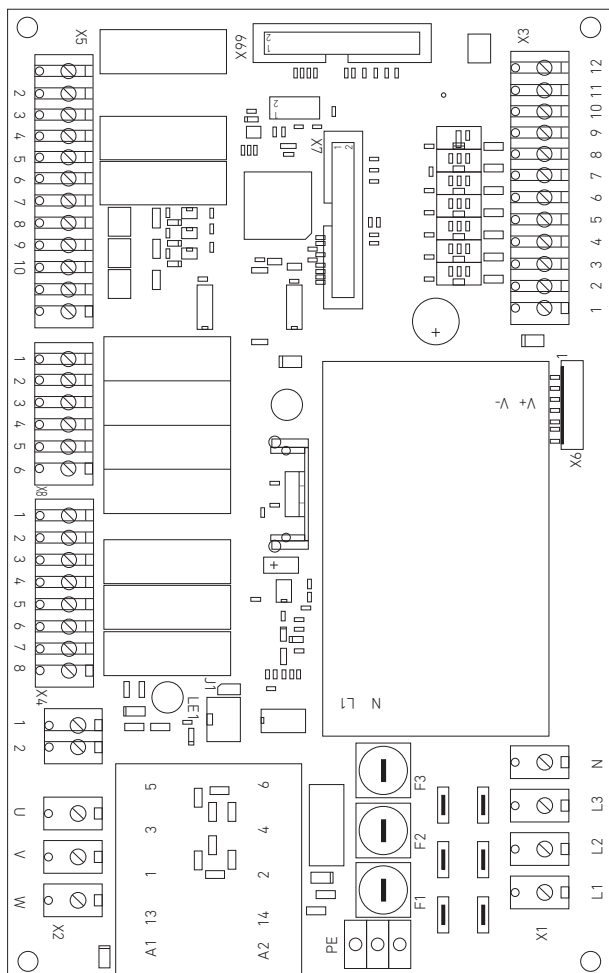

#### Legend:

- X1: Mains connection
- PE: PE connection
- HS1 to HS6: Main switch
- X2: Connection of hydraulic power unit / emergency stop
- X3: Connection of command devices / sensors
- X4: Connection of tubular motor / external signal devices
- X5: Connection of valves and gate
- X6: Connection of pushbuttons
- X7: Connection of LCD monitor
- X8: Connection of traffic lights
- X99 is not used
- F1 to F3: Hydraulic power unit fuse protection
- J1: Jumper rotating field / phase failure test

## 2.6 Technical data RS 301

### Mechanical and electrical data

Housing dimensions	215 x 275 x 190 mm
Mounting	Vertically, on the wall; Min. height of 1,100 mm
Supply via L1, L2, L3, N, PE :	400V/3~, 50/60 Hz 230V/3~, 50/60 Hz 90 - 250 V/1~, 50/60 Hz
Customer-provided fuse/ breaker	max. 10 A K-characteristic
Hydraulic power unit connected load	max. 2.2 kW / 8 A Factory fuse protection 6.3 A T must be aligned with the respective hydraulic power unit.
Controller internal consumption	max. 300 mA
Control voltage	24 V DC, max. 2.5 A; Protected by automatically resetting fuse for external sensors
Controller inputs	24 V DC; All inputs are to be connected potential-free. Minimum signal duration for input controller command >100 ms
Controller outputs	24 V DC, max. 2.2 A incl. Valves
Valves	24 V DC, max. 0.6 A / 100% ED
LCD monitor	Only an original LCD monitor from Marantec may be used (Article no. 91447)
Relaisausgänge	If inductive loads are connected (e.g. further relays or brakes), these must be equipped with corresponding interference suppression measures (e. g. Free- wheeling diodes, varistors, RC elements). Work contact potential-free; min. 10 mA; max. 230 V AC / 4A. <i>Contacts that have been used for power switching can no longer be used for switching low currents.</i>
Temperature range	Operation: -10 °C to +55 °C Storage: -25 °C to +80 °C
Humidity	Up to 80% non-condensing
Vibrations	Low-vibration mounting, e.g. on a masonry wall
Protection grade	IP 44
Weight	ca. 5.5 kg



## 3. Installation

### 3.1 Safety instructions for installation

#### **WARNING!**

##### **Danger due to a failure to observe the installation instructions!**

This chapter contains important information for the safe assembly of the product.

- Read this chapter through carefully before assembly.
- Follow the safety instructions.
- Perform the assembly as described.

Assembly by qualified specialist personnel only.

→ "1.2.2 Specialist personnel"

- It is vital that the system is disconnected from the power supply before any wiring work.
- Ensure that the electricity supply remains disconnected throughout any wiring work.

After system installation, the persons responsible for operating the system or their representatives must be familiarised with operating the system.

- Children must not play with the control unit or command devices.
- No persons or objects are permitted inside the operating range of the dock leveller.
- All available emergency command devices must be tested.
- Pay attention to any parts of the system that could cause crushing or shearing damage.
- Never insert your hands into a running dock leveller or moving parts.
- Select the cable types and cross-sections in accordance with the applicable regulations.
- An all-pole main switch must be used for fixed connections.

The following points must be correct to guarantee fault-free functioning:

- The loading bridge is fitted and functional.
- The command and safety devices are fitted and functional.
- The control housing with the RS 301 controller is fitted.

 The instructions from the respective manufacturer must be observed for the installation of the loading bridge, the hydraulic unit and the command and safety devices.

### 3.2 Mains connection

#### **Prerequisites**

The following points must be correct to guarantee the function of the controller:

- The mains voltage must correspond with the information on the type plate.
- The mains voltage must correspond with the voltage of the hydraulic power unit.
- In the case of three-phase power, this must have a clockwise rotating field.
- With three-phase power connection, only triple block circuit breakers (10 A) shall be used.
- The neutral conductor must be connected.

#### **ATTENTION!**

##### **Malfunctions due to improper installation of the controller!**

Incorrect installation or incorrect wiring can lead to faults in the control unit.

- Before switching on the controller for the first time but after all of the wiring has been completed, it is necessary to check that all motor connections on the motor and controller sides are tight.
- All control voltage inputs are galvanically separated from the supply.
- The control and load lines of the connected hydraulic unit must be double-insulated along their entire length.

### Mains connection and hydraulic power unit

3.2 / 1

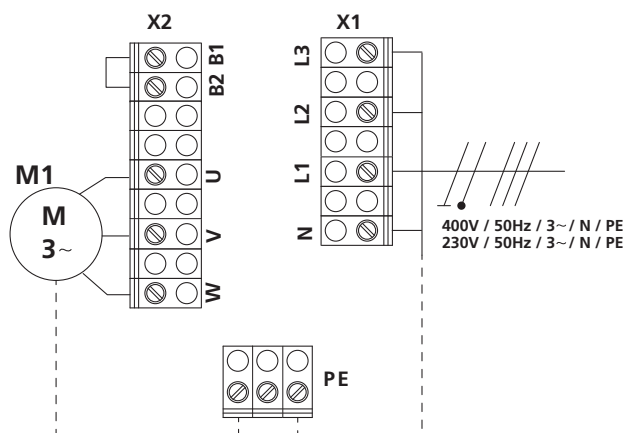

**Legend:**

- M1: Motor (hydraulic power unit)
- X1: Mains connection terminal strip
- X2: Hydraulic power unit terminal strip
- F1-3: Hydraulic power unit fuse protection (max. 8 A)

**⚠ ATTENTION!**

**Malfunctions due to unprofessional protection of the hydraulic unit!**

Fuses with a maximum load capacity of 6.3 A are used ex works for the internal protection of the hydraulic power unit. These must be adjusted to the unit on site if necessary. The top limit here lies at 6 A and must not be exceeded.

**NOTE:**

The RS 301 is equipped with an integrated rotating field test and phase failure detection. These monitoring functions can be activated or deactivated via jumper J1. With activation (only with supply with 400V/3~ and jumper J1 plugged in), a clockwise rotating field must be present. Otherwise LED 1 is off and the system cannot be put into operation. With supply with 230V/3~ the rotating field test and phase failure detection cannot be used and jumper J1 must be unplugged. If jumper J1 remains plugged in, the system cannot be put into operation.  
→ "4.4 Rotating field test / Phase failure detection"

### Main switch connection

3.2 / 2

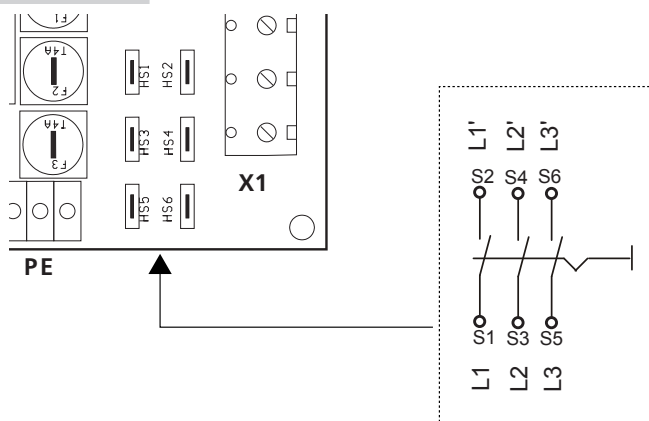

### 3.3 24 V DC for external devices

#### Terminal strip X5

3.3 / 1

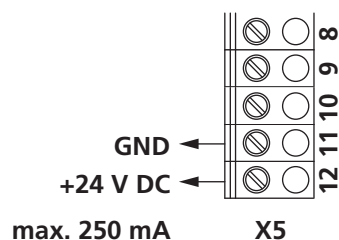

### 3.4 Connection of emergency stop device

#### Terminal strip X2

3.4 / 1

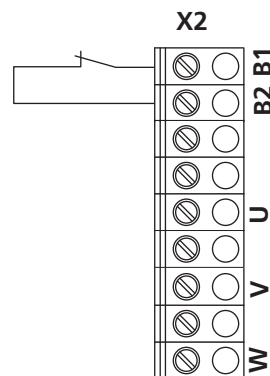



### 3.5 Connection of valves

It is possible to connect up to 3 valves (24 V DC) and actuate these directly (max. 600 mA per valve).  
The supply is realised via the connection terminals.  
The function is specified via the "VALVE VERSION" parameter.  
The feed lip or hinged lip function is selected via FACTORY MODE 1 or FACTORY MODE 2.

#### Terminal strip X5

3.5 / 1

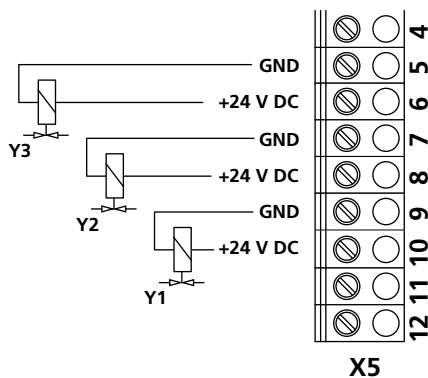

### 3.6 Connection of pushbuttons

#### Terminal strip X6

3.6 / 1

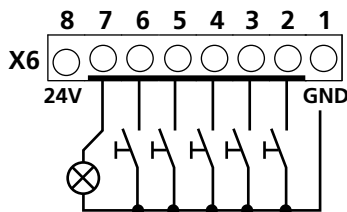

#### Legend:

- 2: LIP FORWARDS button
- 3: LIP BACK button
- 4: RAISE button
- 5: AUTO-RETURN (AR) button
- 6: LOWER button
- 7: LED

#### NOTE:

The LED is optional and is an indicator for the supply voltage of the control in the standard variant.  
However, with special customer-specific software the LED can also indicate other operational states.

### 3.7 Connection of signal traffic lights

It is possible to connect up to 4 signal traffic lights.  
The supply is realised via the connection terminals and it is possible to select between 24 V DC and 230 V AC. The functions are derived from the settings of the parameters:

- TRAFFIC LIGHT MOD
- WHEEL BLOCK
- TRUCK SENSOR
- SHELTER
- SHELTER TIME
- BRIDGE FREE
- FREE INPUT

#### 24 V DC version

#### Terminal strip X5 and X8

3.7 / 1

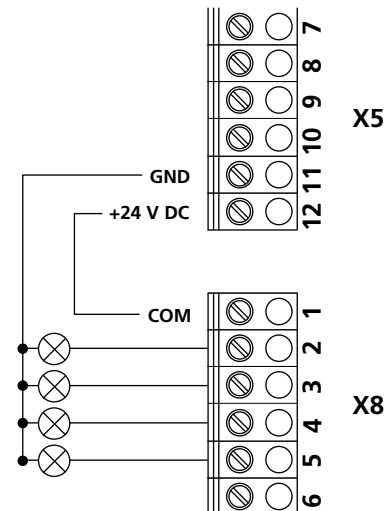

### 230 V AC version

#### Terminal strip X4 and X8

3.7 / 2

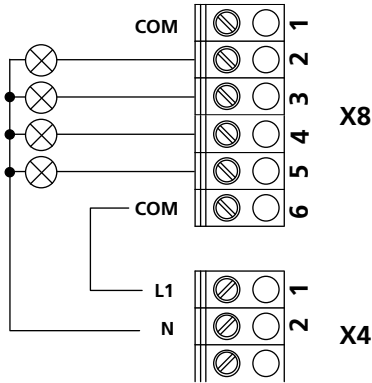

#### Legend:

GREEN internal traffic light:	Terminal 2
RED internal traffic light:	Terminal 3
GREEN external traffic light:	Terminal 4
RED external traffic light:	Terminal 5

### 3.8 Connection of loading bridge limit switch

The connection can be optionally used.

- Implementation as NO contact.
- Active if the extendable lip is fully retracted.
- Release for lowering into the standby position (Home).
- The unit is switched off.
- The external green traffic light switches on (if available).
- The truck can depart.

#### Standard:

Procedure only via time settings.

#### Terminal strip X3

3.8 / 1

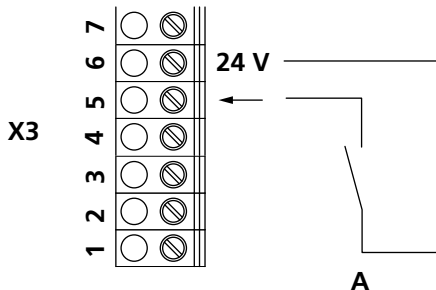

A: NO contact

### 3.9 Connection of approach sensor

Optical and acoustic collision protection through an approach sensor.

- A vehicle drives in front of the door.
- The approach sensor is activated.
- A warning signal sounds.
- The red external traffic light switches on.
- The red internal traffic light flashes.
- Actuation of the loading bridge is enabled.
- Gate interlocking can be optionally activated.

The function must be activated in the input via the TRUCK SENSOR parameter.

The sensor can be realised as an NO contact or as a PNP Open Collector

#### NO contact

#### Terminal strip X3

3.9 / 1

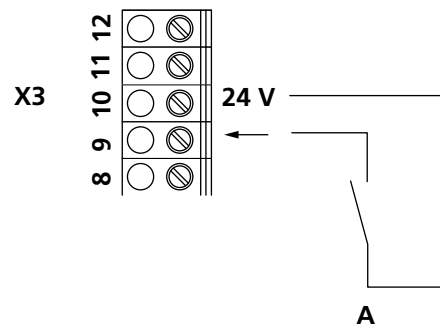

#### PNP Open Collector

#### Terminal strip X3

3.9 / 2

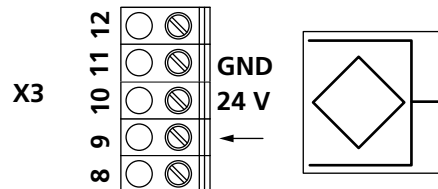

### 3.10 Wheel block connection

The wheel block serves to secure the vehicle during the loading process.  
The function must be activated in the input via the WHEEL BLOCK parameter.  
The wheel block can be realised as an NO contact or as a PNP Open Collector.

#### NO contact

##### Terminal strip X3

3.10 / 1

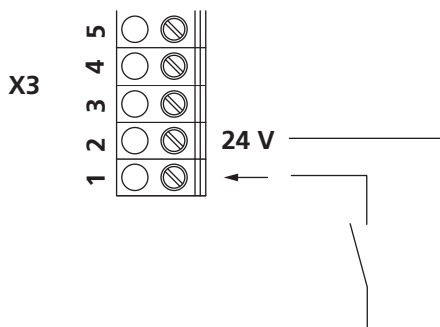

#### PNP Open Collector

##### Terminal strip X3

3.10 / 2

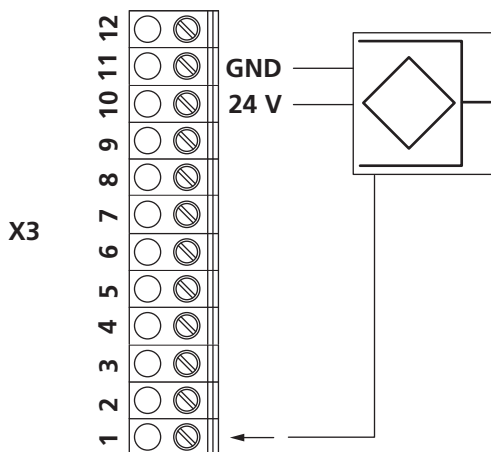

### 3.11 Connection of the tubular motor / fan (shelter function)

The area between the truck loading bay and the building interior can be sealed. This can consist of an inflatable seal (fan) or a winding seal (tubular motor).

The outlet for the tubular motor is generally functioning if the shelter function has been activated (SHELTER parameter).

#### Tubular motor

##### Terminal strip X4

3.11 / 1

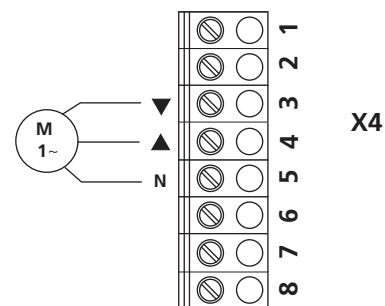

#### Fan with auxiliary contactor (optional)

This is only used if the output at X4 /6-7 is used for a signal horn or a loading light and the gate seal must additionally take place via a fan. Otherwise the fan is connected to X4/6-7.

→ "3.12 Connection of signal horn / loading light / Fan (shelter function)"

##### Terminal strip X4

3.11 / 2

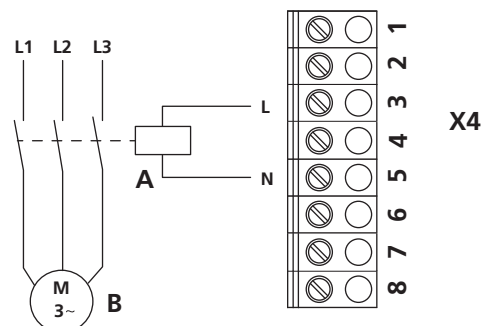

A: Additional contactor for actuating the fan.  
Not included in the standard scope of supply.

B: The motor (fan) can be single-phase or three-phase by design.

### 3.12 Connection of signal horn / loading light / Fan (shelter function)

To safeguard the loading process, it is possible to either select a signal horn or a loading light.

In order to seal the area between the HGV loading bay and the building interior, it is possible to connect an inflatable seal (fan). The function must be activated in the input via the parameter HU/LI/SH.

#### Signal horn

#### Terminal strip X4

3.12 / 1

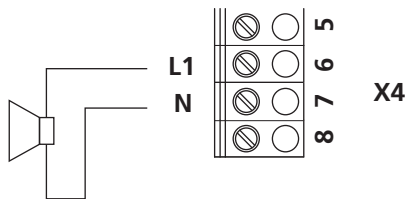

#### Loading light

#### Terminal strip X4

3.12 / 2

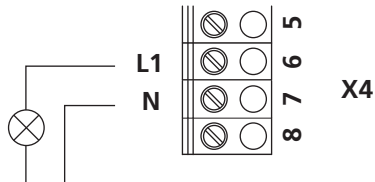

#### Fan

#### Terminal strip X4

3.12 / 3

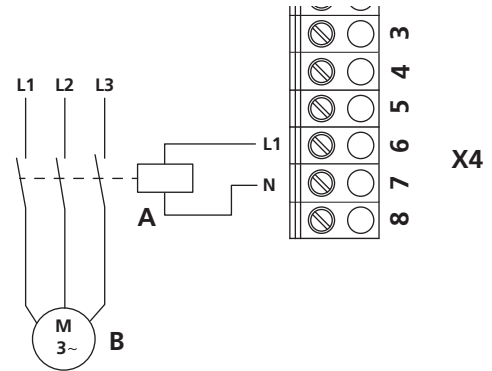

If this output is used for a signal horn or loading light, actuation of the fan takes place via X4/3+5.

→ "3.11 Connection of the tubular motor / fan (shelter function)"

A: Auxiliary contactor for actuation of the fan. Not included in the standard scope of supply.

B: The motor (fan) can be single-phase or three-phase by design.

### 3.13 Connection to the gate controller

The RS 301 can be linked with a gate controller to control or interlock the loading bridge and gate controller in relation to each other.

#### Bridge release

The loading bridge controller can be interlocked via a potential-free contact of the gate system or via a sensor.

The polarity of the signal can be adjusted.

Actuation can take place via an NO or NC contact and can be set with the ENABLE +/- parameter.

The loading bridge can only be operated if a gate system release is present. If release is withdrawn during operation of the loading bridge, both traffic lights switch to red and an acoustic warning signal sounds (only if the signal horn is connected).

#### NC contact

##### Terminal strip X3

3.13 / 1

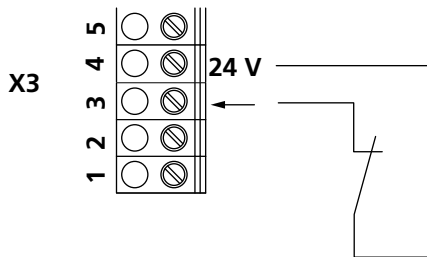

#### NO contact

##### Terminal strip X4

3.13 / 2

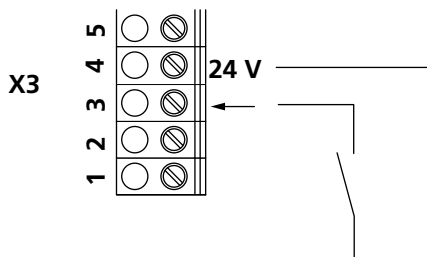

#### NOTE:

If no connection to a gate control is established, either terminals 3+4 must be bypassed or the ENABLE +/- parameter must be set to MOD2.

#### PNP Open Collector

##### Terminal strip X3

3.13 / 3

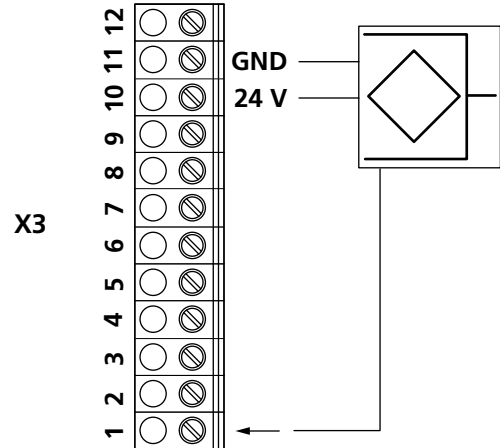

#### Gate release

Potential-free contact for interlocking the gate system. The contact is opened as soon as the loading bridge is no longer in the standby position. The gate system is then blocked.

##### Terminal strip X5

3.13 / 4

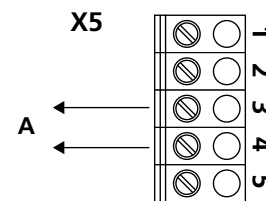

A Gate system safety circuit

### Close gate command

The gate system can be closed automatically after the loading procedure via a potential-free contact (NO). The function is determined according to the setting of the SHELTER parameter.

#### SHELTER parameter = MOD 4

The contact is only closed in the resting position (HOME) of the loading bridge and is passed on to the gate control (X3/9-10) as a pulse (1 sec.) in order to trigger direct closing.

#### SHELTER parameter = MOD 5

The contact is permanently closed after the shelter time has passed, and ensures that the gate remains open via input 1 of the gate control (X4/9-10 - MOD4). After loading, the contact is opened again and the gate closes after the set open time has passed.

### Terminal strip X5

3.13 / 5

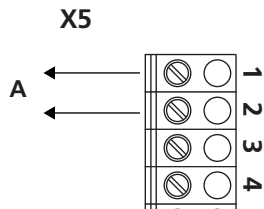

A Gate system CLOSED command  
→ "7.2 Input operating mode"

### 3.14 Connection of free input

The free input can be individually configured. The function and type of circuitry can be selected in the input via the parameter FREE 1.

### Terminal strip X3

3.14 / 1

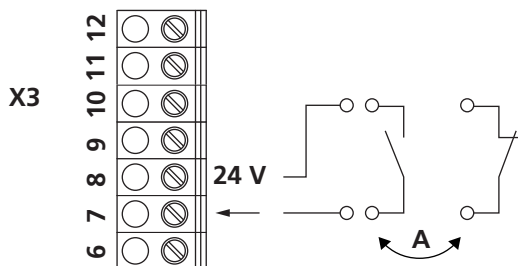

A: optionally



## 4. Functional description

### 4.1 Operation of the loading bridge

#### 4.1.1 Version with feed lip (FACTORY MODE 1)

The loading bridge can be raised with the raise pushbutton in 'dead-man' mode. The loading bridge must be lifted for the **1st raise** time as a minimum.

After reaching the optimum position, the button can be released. The loading bridge remains in the **adjustment** position for 5 seconds. The lip should be positioned during this period. If no buttons are actuated, the loading bridge drops back to the standby position.

The lip can be positioned using the lip IN/OUT buttons in dead-man mode. With this, the lip must be extended for the time **MIN TIME EXTEND LIP** as a minimum. Once the time **MAX TIME EXTEND LIP** is reached, the lip stops automatically. After releasing the button, the loading bridge lowers to the loading position (floating position).

If the position of the lip requires correction during the loading process, this can be performed directly with the buttons Lip IN/OUT. With this, the loading bridge is automatically raised for 1 second before the lip drives in or out.

After every setting of the **LOWER** parameter, the bridge drops back to the floating position automatically or after the LOWER button has been pressed.

#### 4.1.2 Version with hinged lip (FACTORY MODE 2)

When the LIFT cover button is pressed, the dock leveller is lifted in dead man's mode. The lip folds out automatically into the top end position. As soon as the lip is fully extended, the button can be released. The dock leveller then automatically lowers into the loading position (floating position).

When current detection is active, the top dock leveller position (lip folded out) is detected when lifting from the resting position. If the top end position is not approached for at least 2 seconds, the control unit assumes that the lip is not fully folded out and lowers the leveller back into the resting position. If this position is approached for longer than 2 seconds, the leveller lowers into the floating position.

### 4.2 Automatic Return (AR)

#### 4.2.1 Version with feed lip

After the loading process is complete, the loading bridge returns to the standby position by means of the AR button. The procedure is carried out automatically.

##### AR – Version 1: (AUTO-RETURN MOD 2 parameter)

- The loading bridge is lifted for the time **AR-RAISE 1**.
- The lip is retracted up to the value **MIN TIME EXTEND LIP**.
- The loading bridge is further lifted for the time **AR-RAISE 2**.
- The lip is fully retracted.
- The loading bridge lowers into the standby position.

##### AR – Version 2: (AUTO-RETURN MOD 4 parameter)

- The loading bridge is raised for the time **AR-RAISE 1** or **AR-RAISE 2** (the greater time value is applied here).
- The lip is fully retracted.
- The loading bridge lowers into the standby position.

#### 4.2.2 Version with hinged lip

Once loading is complete, the dock leveller is reset to the resting position by pressing the AR button.

The AR function runs automatically when the button is pressed.

##### Current-controlled AR function (standard)

- The dock leveller is lifted into the top end position (this position is detected via the current detection) OR for the time **AR Lift 1**.
- If the use of current detection is required, the selected time **AR Lift 1** must be sufficiently long.
- The dock leveller lowers for the time **AR Lower 1**.
- The dock leveller is lifted once more for the time **AR Lift 2**.
- The dock leveller lowers into the resting position.
- Once the time **AR Lower 2** has elapsed, the program sequence continues.

##### Time-controlled AR function:

- The dock leveller is lifted for the time **AR Lift 1**.
- The dock leveller lowers for the time **AR Lower 1**.
- The dock leveller is lifted once more for the time **AR Lift 2**.
- The dock leveller lowers into the resting position.
- Once the time **AR Lower 2** has elapsed, the program sequence continues.

### 4.3 Start-up interlocking

The RS 301 controller has integrated start-up interlocking. This safety function ensures that the stop valve is switched off and therefore that the loading bridge is locked.

If, during actuation of the loading bridge,

- an emergency stop signal is issued, the display shows the message **EMERGENCY STOP**. The error message can be acknowledged with the **RAISE** or **AR** buttons. After this, **ADJUSTMENT** appears in the display.
- the power supply is interrupted, once the power is switched back on again **ADJUSTMENT** appears in the display.

It is now possible to move the loading bridge again using the direction buttons, and place it back in the floating position if necessary.

### 4.4 Rotating field test / Phase failure detection

The RS 301 controller has integrated rotating field monitoring. When the controller is switched on, a check takes place to determine whether a clockwise rotating field is present. If this is not the case, the contactor does not activate.

The circuit is also safeguarded against a phase drop-out. This is also checked when the controller is switched on.

Both errors are signalled through LED 1.

The LCD monitor shows **ERROR ROTATING FIELD**.

Both functions can be deactivated via jumper 1.

4.4 / 1



- A: Rotating field / phase failure monitoring not active  
(Jumper plugged in)
- B: Rotating field / phase failure monitoring active  
(Jumper not plugged in)

**NOTE:**

The rotating field test and phase failure detection only operate if supplied with 400V/3~. If the supply is 230V/3~ jumper J1 must be unplugged, otherwise the system cannot be put into operation.

### 4.5 Current monitoring

The control RS 301 has integrated current monitoring for the motor of the hydraulic unit.

Depending on the height and characteristics of the HGV loading bay and/or setting of the div. action times, the loading bridge can reach its mechanical stop in various movement directions, even if the pre-set runtime of the respective movement has not fully elapsed. However, the cause of excessive mechanical resistance can also be a pallet, which is still located on the bridge or directly driving the lip against the HGV.

In order that the hydraulic unit does not run on unnecessarily, if this does occur then the current monitoring ensures the unit switch-off and lowering into the floating position.

#### 4.5.1 Version with feed lip (FACTORY MODE 1)

In order that the current monitoring works faultlessly, it is initially necessary to adjust the **CURRENT SWITCH-OFF** to the respective hydraulic unit.

The maximum permissible deviation of the motor current in % is set here.

Monitoring is only active

- when the lip is driven out prior to the loading process
- when lifting during automatic resetting in the resting position (Auto-Return)

This limit value can only be determined if the parameter **MAX LIP OUT** is set to a time value that is higher than the time required to fully drive the lip out.

In this way the lip runs against the mechanical stop when extending and the motor current of the hydraulic unit increases.

The parameter **CURRENT SWITCH-OFF** (in %) must now be set back sufficiently that the current monitoring triggers upon driving the lip against the mechanical stop, the hydraulic unit switches off and the bridge lowers directly into the floating position.

Afterwards, the parameter **MAX LIP OUT** must be set to a sufficiently low value that the lip cannot drive against the mechanical stop.

#### 4.5.2 Version with hinged lip (FACTORY MODE 2)

##### Detection of the top position (lip folded out) when lifting from the resting position

When current detection is active, the top dock leveller position (lip folded out) is detected when lifting from the resting position. If the top end position is not approached for at least 2 seconds, the control unit assumes that the lip is not fully folded out and it lowers the leveller back into the resting position. If this position is approached for longer than 2 seconds, the leveller lowers into the floating position.

##### Detection of the top position during Auto Return

With **AR LIFT 1** the top end position is detected by means of current detection OR the set time. Following detection of the top end position, the leveller lowers into the resting position automatically.

#### 4.6 Time and current measurement

In the MAINTENANCE and AUTOMATIC operating modes, different times and current values are displayed, which pertain to the internal measurements of the control.

These values primarily serve as information for the service technician during commissioning or can help to support the diagnostic process in case of a fault.

##### MAINTENANCE mode

###### 4.6 / 1

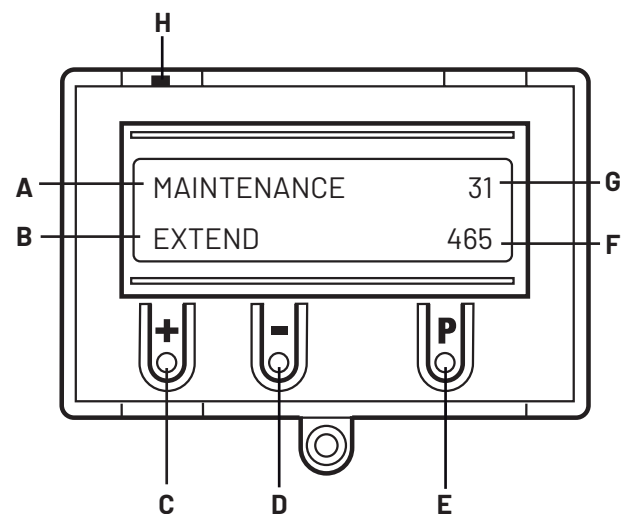

- A: Display of the function that is currently active.  
EXTEND (example)  
RETRACT  
RAISE
- B: Display of the time only for the duration of the respective function (example 31 = 3.1 seconds).
- C: Display of the current only for the duration of the respective function.

The display describes an abstract value that is in relation to the current consumption of the hydraulic unit. This value does not constitute the actual motor current in A, but it does enable conclusions to be drawn regarding the characteristic curve for the current.

If the motor current doubles for example, the displayed value also doubles.

With this the service technician is able to determine whether

- motor current is flowing,
- the characteristic curve for the current makes greater jumps during a movement (this would indicate a mechanical problem),
- the values are approximately identical in a comparison with multiple loading bridges of the same type.

## AUTOMATIC mode

4.6 / 2

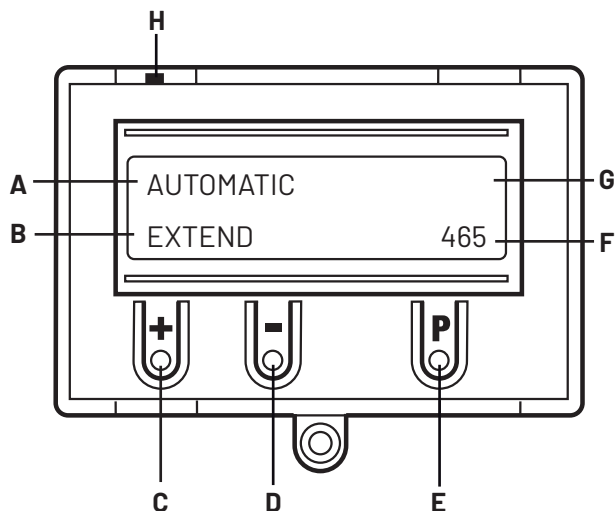

- A: Display of the function that is currently active.  
EXTEND (example)  
AUTO-RETURN
- B: Display of the current only for the duration of the respective function. With AUTO-RETURN, the current measurement is only performed during the RAISE function.

The display describes an abstract value that is in relation to the current consumption of the hydraulic unit. This value does not constitute the actual motor current in A, but it does enable conclusions to be drawn regarding the characteristic curve for the current.

If the motor current doubles for example, the displayed value also doubles.

With this the service technician is able to determine whether

- motor current is flowing,
- the characteristic curve for the current makes greater jumps during a movement (this would indicate a mechanical problem),
- the values are approximately identical in a comparison with multiple loading bridges of the same type.

If the loading bridge is in the floating position, the time values are displayed, which were measured during RAISE and EXTEND (only FACTORY MODE 1).

4.6 / 3

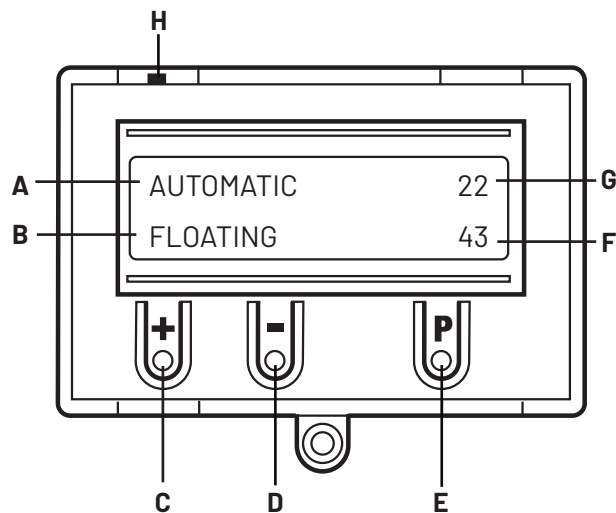

- A: Display of the time only for the duration of raising  
(Example 22 = 2.2 seconds)
- B: Display of the time only for the duration of extending  
(Example 43 = 4.3 seconds)

## 5. Programming

### 5.1 Overview of the LCD monitor

#### **ATTENTION!**

##### **Property damage due to improper installation!**

Incorrect installation can result in damage to the LCD monitor or the control unit.

- The display must be plugged in whilst de-energised.
- Only a display from Marantec (article number 91447) may be used.

5.1/1

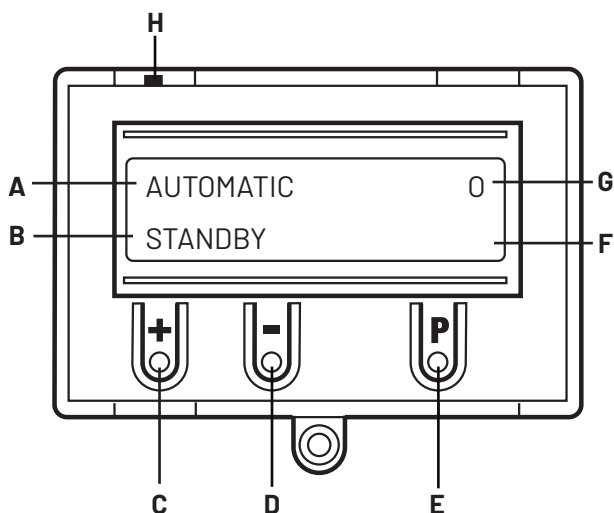

#### **Explanation:**

- A: Operating mode / diagnostics info
- B: Parameters / diagnostics info
- C: (+) button
- D: (-) button
- E: (P) button
- F: Value/status
- G: Value/status
- H: Jumper

If the jumper H is removed, the (+), (-) and (P) buttons no longer function.

The display continues to function.

### 5.2 LCD monitor operating modes

With the LCD monitor, the controller has four operating modes:

1. AUTOMATIC
2. INPUT
3. DIAGNOSTICS
4. MAINTENANCE

The control unit remains in the selected operating mode until the button (P) is used to select a different operating mode. The system does not automatically switch back to another operating mode.

#### **Operating mode 1: AUTOMATIC**

The loading bridge is driven in AUTOMATIC mode.

Display:

- Display of the function being carried out
- Display of possible faults
- Display of the current monitoring (factorised) whilst the lip extends
- Display of the time that was required for extending and raising

#### **Operating mode 2: INPUT**

The values of various parameters can be changed in INPUT mode.

Display:

- Displays the selected parameter
- Displays the status/value set

#### **Operating mode 3: DIAGNOSTICS**

System-specific checks can be interrogated in DIAGNOSTICS mode.

Display:

- Display of the check
- Display of the check status

#### **Operating mode 4: MAINTENANCE**

In MAINTENANCE mode, the loading bridge can be operated via the integrated housing buttons. MAINTENANCE mode is intended for start-up only. No floating position is realised here. All safety devices (apart from emergency stop) are ignored. Using the AR button it is possible to lower the loading bridge in the "dead-man" function.

Display:

- Display of the functions being carried out.
- Display of the current monitoring (factorised) during retracting, extending and raising.
- Display of the time that was required for retracting, extending and raising.

## 6. Navigator

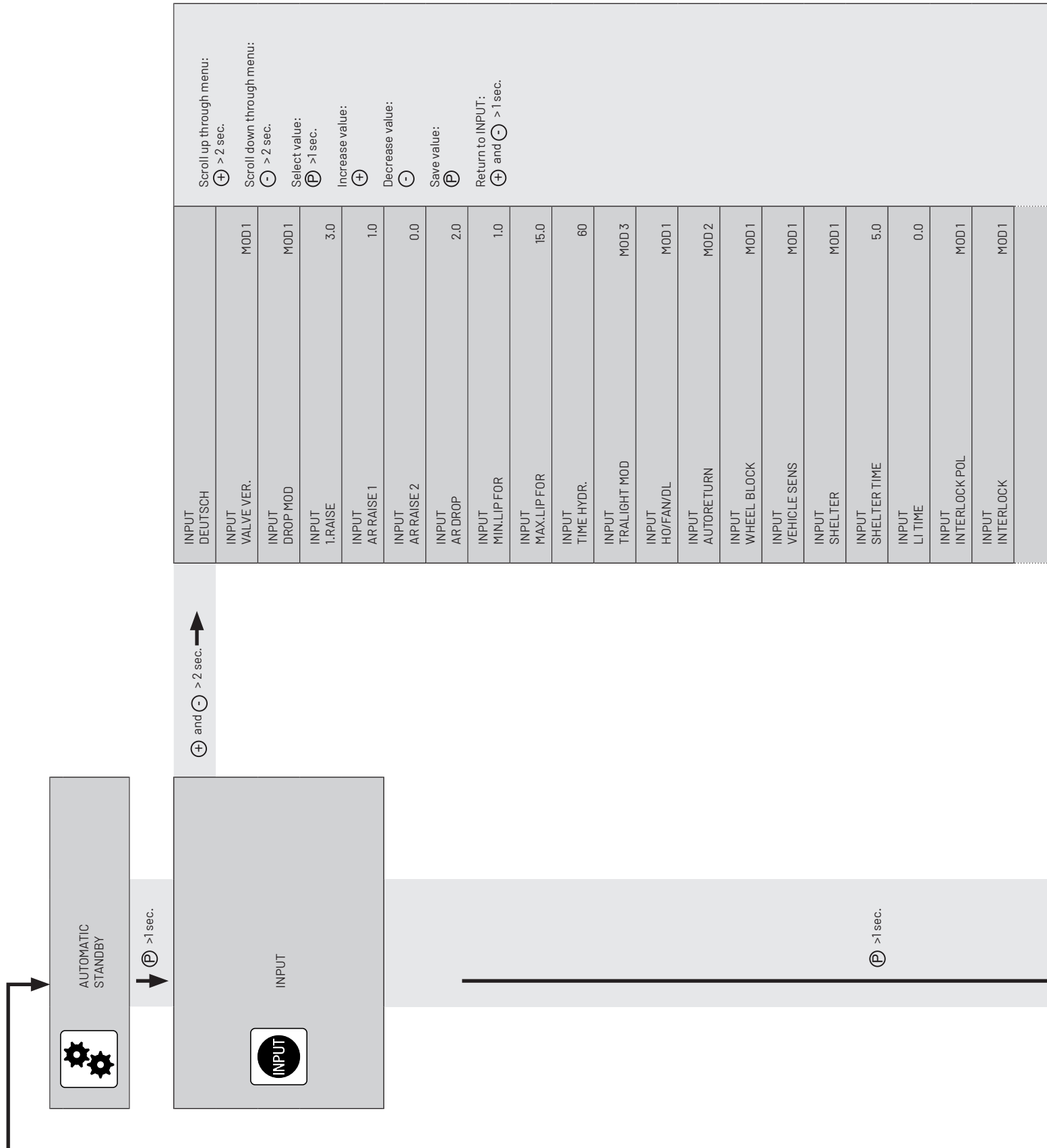



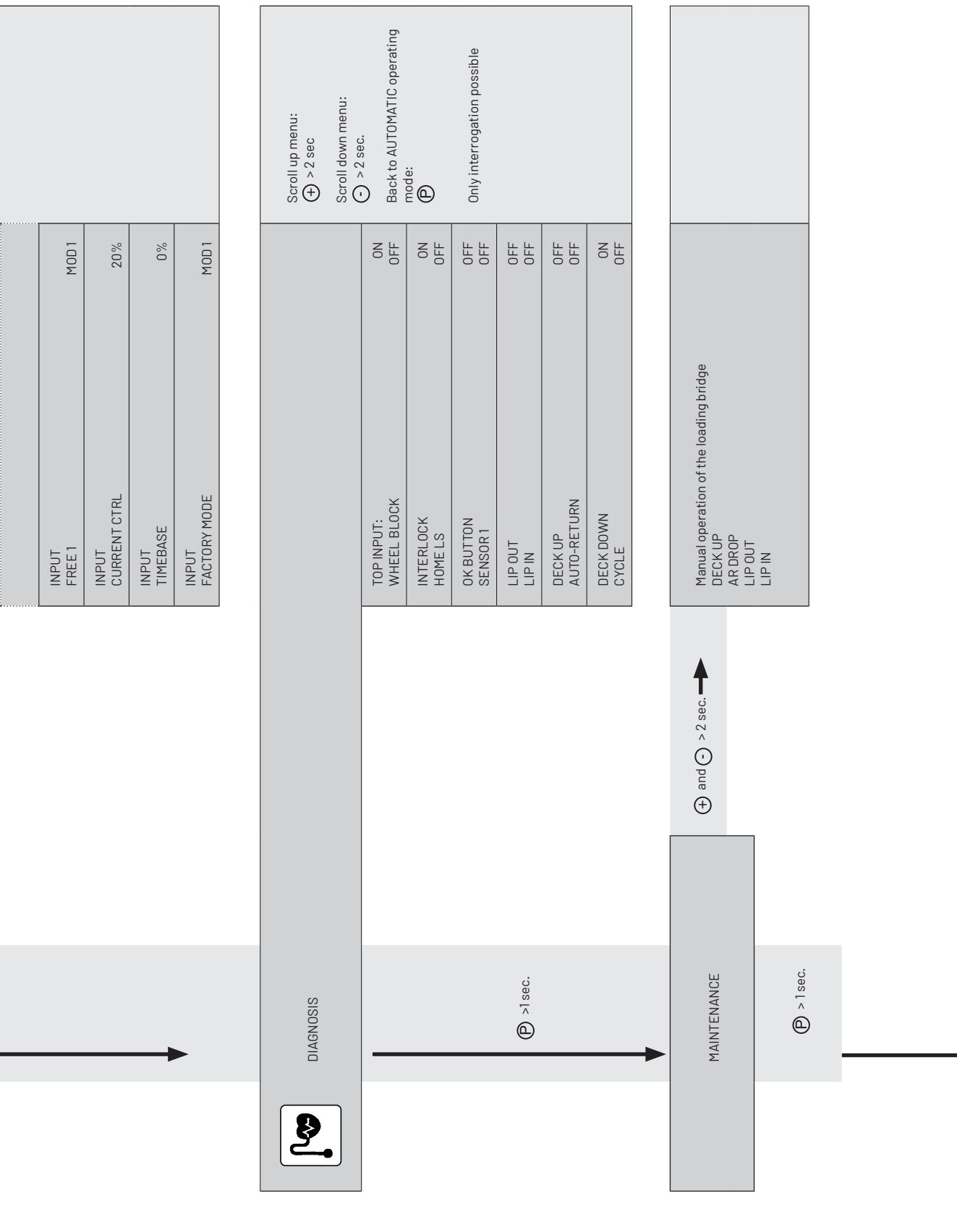

## 7. Functional overviews

### 7.1 Automatic mode



Display	Description
AUTOMATIC STANDBY	The loading bridge is in the standby position.
AUTOMATIC FLOATING	The loading bridge is in the loading position.
AUTOMATIC EMERGENCY STOP	The loading bridge is in the EMERGENCY STOP position. Resetting in the floating or resting position, the error message must first be acknowledged with the RAISE or AUTO-RETURN button. The display shows ADJUSTMENT and the loading bridge can be moved with the direction buttons again.
AUTOMATIC ADJUSTMENT	With loading bridges with an extendable lip, the lip can be extended or retracted in this mode.
AUTOMATIC 1. RAISE	The loading bridge is lifted out of the standby position (home position).
AUTOMATIC DECK UP	The loading bridge is raised. Appears after the time 1.RAISE has been exceeded.
AUTOMATIC LIP OUT	The extendable lip is extended.
AUTOMATIC LIP IN	The extendable lip is retracted.
AUTOMATIC AUTORETURN	Auto-return cycle runs. Automatic reset in the standby position (home position).
AUTOMATIC SHELTER <->	The shelter time runs (inflate or deflate).

## 7.2 Input operating mode

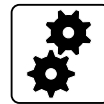

### 7.2.1 Version with feed lip (FACTORY MODE 1)

Function	Description	Adjustment options	Factory setting
DEUTSCH	Selection of the menu language	DEUTSCH ENGLISH NEDERLANDS FRANCAIS ESPANOL ITALIANO	DEUTSCH
VALVE VER.	Selection of the predefined valve functions.  MOD1: 3 valves Standard MOD2: 3 valves Special MOD3: 2 valves Standard MOD4: 2 valves Hafa MOD5: 3 valves Zuccaro MOD6: 3 valves Laweco MOD7: 3 valves Cobelux MOD8: 2 valves Special  → "7.3 Function tables for valve actuation"	MOD 1 – MOD 8	MOD 1
DROP MOD	Setting how the loading bridge should be lowered into the floating position. MOD 1: Automatic lowering MOD 2: Forced lowering via LOWER button (only with 4 direction buttons). Through the pulse command the loading bridge is automatically lowered into the floating position. MOD 3: Forced lowering via LIP BACK (only with 3 direction buttons). Through the pulse command the lip retracts briefly and is then lowered into the floating position automatically. MOD 4: Forced lowering via LOWER button (only with 4 direction buttons). The loading bridge is lowered manually by a continuous command from the lower button, until the sensor mounted on the bridge detects the truck loading bay. (LOWER sensor -> Free input X3 / 7-8)	MOD 1 – MOD 4	MOD 1 – MOD 4
1. RAISE	From the standby position, the loading bridge must be raised by the first raise time before the lip can be extended. This function serves to protect the mechanism.	0.5 – 5 sec.	3 sec.
AR RAISE 1	Time for first raising from the loading position (floating position) during the AUTO-RETURN process. This ensures that the extendable lip is free.	0.5 – 25 sec.	1 sec.
AR RAISE 2	Time for further raising the loading bridge during the AUTO-RETURN process.	0 – 20 sec.	0 sec.

Function	Description	Adjustment options	Factory setting
AR DROP	Time for lowering into the standby position during the AUTO-RETURN process. The time influences switching of the traffic lights and gate release.	0 – 16 sec.	2 sec.
MIN.LIP FOR	Minimum time for which the extendable lip must be extended. This function serves to protect the mechanism.	0.5 – 5 sec.	1 sec.
MAX.LIP FOR	Time required to fully extend the extendable lip. After this time has passed, extension stops and the loading bridge lowers. The correct time that the extendable lip requires must be determined in advance (stopwatch). This can take place in AUTOMATIC mode with a stopwatch or in MAINTENANCE mode by reading out the monitor display. → "4.6 Time and current measurement"	1 – 60 sec.	15 sec.
TIME HYDR.	Maximum run-time of the hydraulic power unit. The run-time monitoring of an individual movement serves to avoid an overload with sticking buttons or defective limit switches.	0 – 254 sec.	60 sec.
TRALIGHT MOD	Function of the external traffic lights after the loading process. The loading bridge is back in the standby position (HOME position).  MOD 1 Always switched off. MOD 2 In when in standby position. MOD 3 Out after 5 minutes when in standby position. MOD 4 On in the resting position without end position query for gate. For ramps without gate connection. MOD 5 Off after 5 minutes in the resting position without end position query for gate.	MOD 1 – MOD 5	MOD 3
HO/FAN/DL	Actuation of warning signal, fan (shelter function) and loading light. The set MOD pertains to the components connected to X4 / 3-7.  MOD 1: Horn Produces a warning signal if the wheel block is removed during loading for example. MOD 2: Fan Actuation of a fan for the gate seal during the loading process (shelter function). This MOD sets itself automatically if MOD2 or MOD3 have been selected in the SHELTER parameter. MOD 3: Automatic loading light When lifting for the first time, the light switches on and remains on until the loading bridge is back in the standby position (HOME). MOD 4: Manual loading light The loading light can be manually switched on and off via the LOWER button. A precondition for this is the setting MOD1 in the LOWER parameter.	MOD 1 – MOD 4	MOD 1

Function	Description	Adjustment options	Factory setting
AUTO-RETURN	<p>The AUTO-RETURN process describes the automatic resetting of the loading bridge after the loading process in the standby position (HOME). The process is triggered by pressing the AR button (blue).</p> <p>MOD 1: Auto-return function deactivated.            MOD 2: Auto-return function activated.            MOD 3: Auto-return also via the LIP BACK button.            If the button is pressed for longer than 4 seconds, the AUTO-RETURN process also starts.            MOD 4: Shortened auto-return cycle without first retraction.            → "4.2 Automatic Return (AR)"</p>	MOD 1 – MOD 4	MOD 2
WHEEL BLOCK	<p>MOD 1: Wheel block function deactivated.            MOD 2: Wheel block function activated.            if the wheel block is removed during the loading process, the traffic lights switch to red and the horn signals this.            MOD 3: Wheel block function activated.            if the wheel block is removed during the loading process, the keypad is blocked.</p>	MOD 1 – MOD 3	MOD 1
VEHICLE SEN	<p>Function of the approach sensor (X3/9-10) when driving a vehicle up to the loading bridge.</p> <p>MOD 1: Deactivated.            MOD 2: Approach sensor activated. Loading bridge without gate controller connected.            Optical and acoustic collision protection through an approach sensor.            If a vehicle drives in front of the gate and activates the approach sensor (continuous signal) a warning signal sounds and the red external traffic light switches on and the red internal traffic light flashes. The loading bridge is released for actuation.            MOD 3: Approach sensor activated. Loading bridge with gate controller connected.            Optical and acoustic collision protection through an approach sensor.            If a vehicle drives in front of the gate and activates the approach sensor (continuous signal) a warning signal sounds and the red external traffic light switches on and the red internal traffic light flashes. The gate function is released and it is possible to actuate the loading bridge as soon as the gate is opened.            MOD 4: Identical to MOD 2, although the ramp is blocked after the actuation of AR until the next docking instance.</p>	MOD 1 – MOD 4	MOD 1

Function	Description	Adjustment options	Factory setting
SHELTER	<p>Activation of a seal to prevent temperature fluctuations between the truck loading bay and the inside of the building. This can consist of an inflatable seal (fan) or a winding seal (tubular motor). The shelter function is only expedient in conjunction with a power-actuated gate and a gate controller connected.</p> <p>MOD 1: Deactivated.            MOD 2: The sealing function is activated via a button command on the free input (X3 / 7-8).            The free input is automatically set to MOD4 (SHELTER button). The parameter HU/LI/SH is automatically set to MOD2 (fan). The output for the tubular motor is also active during the shelter time. The gate can now be opened and the loading bridge can be brought into position. Once the loading process has ended, a CLOSE command (X5 / 1-2) is automatically issued to the gate controller. Deactivation of the shelter function takes place when the gate is closed again.            MOD 3: Like MOD2, although the deactivation takes place manually via a second button command on the free input.            MOD 4: The sealing function is activated via a button command on the free input (X3 / 7-8). Actuation of the fan takes place for the duration of the set shelter time via an external contactor on the tubular motor output.            The HU/LI/SH output can now be otherwise used. The gate can now be opened and the loading bridge can be brought into position. Once the loading process has ended, a CLOSE command is automatically issued as a pulse (X5 / 1-2) to the gate controller. Deactivation of the shelter function takes place again via the external contactor for the duration of the shelter time once the gate is closed again.            MOD 5: Like MOD 4, although the gate opens automatically after the shelter time has passed.            (Prerequisite: Connection X5/1-2 with programmable input 1 of the controller CS3x0 / setting MOD4).            Automatic closure of the gate by setting the opening time = 1 sec. (CS3x0).            MOD 6: Like MODE 2 except gate release is only issued once the shelter has been inflated.</p>	MOD 1 – MOD 6	MOD 1
SHELTER TIME	<p>Delay time for the release of the gate after activation of the sealing function (SHELTER).            After the time has passed, the gate can be opened and loading can start.            With deactivation of the sealing function after the loading process, the time starts again and once it has passed the external green traffic light signals that the vehicle can leave the loading bridge.</p>	0 – 254 sec.	5 sec.
LI TIME	<p>If the RZ time is activated, after releasing the EXTEND LIP button the lip is automatically retracted for the duration of the RZ time.            If the value is 0, the function is deactivated.</p>	0 – 2 sec.	0 sec.
INTERLOCK POL	<p>Selection of the release contact. The function of the loading bridge can be blocked or released with the aid of a potential-free contact for the gate controller or an external sensor, and can therefore not be moved with a closed door.</p> <p>MOD 1: NC contact            MOD 2: NO contact</p>	MOD 1 – MOD 2	MOD 1



Function	Description	Adjustment options	Factory setting
INTERLOCK	<p>Function with a blocking of the loading bridge during the loading process.</p> <p>MOD 1: If the loading bridge release is withdrawn during the loading process, the bridge remains in the floating position, the hydraulic power unit is switched off, the keypad for the loading bridge is deactivated and both traffic lights switch to red. If the signal horn is activated, an acoustic warning signal is issued.</p> <p>MOD 2: If the loading bridge release is withdrawn during the loading process, the bridge remains in the floating position and both traffic lights switch to red. If the signal horn is activated, an acoustic warning signal is issued.</p>	MOD1 - MOD2	MOD 1
FREE 1	<p>Function of the freely programmable input (X3/7-8).</p> <p>MOD 1: Deactivated</p> <p>MOD 2: Traffic light acknowledgement. Connection of an acknowledge button with NO contact. The external green traffic light (release of the truck) is only active if the loading bridge is back in the standby position (HOME), the wheel base is removed and the acknowledge button has been actuated. <i>Only in conjunction with an HGV sensor!</i></p> <p>MOD 3: Safety fence with NC contact. If the safety fence is closed, it is not possible to operate the loading bridge.</p> <p>MOD 4: Shelter function. Seal between the truck loading bay and the building interior. Connection of a button with NO contact. If the button is pressed, activation of the sealing function takes place (see SHELTER / SHELTER TIME parameter).</p> <p>MOD 5: LOWER sensor. Connection of a sensor with NO contact. Prerequisite: The LOWER parameter is automatically set to MOD4. The loading bridge only assumes the floating position once the sensor has detected the loading bay of the truck.</p>	MOD1 - MOD5	MOD 1
CURRENT CTRL	<p>The value (in %) is the maximum permissible overshooting of the motor current of the hydraulic power unit when arriving in a limit position. With an overshoot, the unit switches off and the loading bridge assumes the floating position. This parameter must be aligned with the respective unit. If the setting is 0%, current monitoring is deactivated.</p>	0% - 35 %	20 %
TIMEBASE	<p>With this parameter, different speeds of the extendable lip can be set when retracting and extending. A negative value must be selected if the lip is retracted faster.</p>	- 50 % - 50%	0 %
FACTORY MODE	<p>MOD 1: Feed function MOD 2: Hinged lip function</p>	MOD 1 - MOD 2	MOD 1

## 7.2.2 Version with hinged lip (FACTORY MODE 2)

Function	Description	Adjustment options	Factory setting
DEUTSCH	Selection of the menu language	DEUTSCH ENGLISH NEDERLANDS FRANCAIS ESPAÑOL ITALIANO	DEUTSCH
VALVE VER.	Selection of the predefined valve functions.  MOD 1: 1 valve standard MOD 2: 1 valve special MOD 3: 2 valve standard MOD 4: 2 valve special MOD 5: 1 valve (ramp at rest in vertical position)  → "7.3 Function tables for valve actuation"	MOD 1 – MOD 5	MOD 1
AR RAISE 1	Time for first raising from the loading position (floating position) during the AUTO-RETURN process. This ensures that the extendable lip is free.	0.5 – 25 sec.	1 sec.
AR-LOWER 1	Time for lowering the docking leveller only after first lifting during the AUTO RETURN process.	0 – 5 sec.	0 sec.
AR RAISE 2	Time for further raising the loading bridge during the AUTO-RETURN process.	0 – 20 sec.	0 sec.
AR-LOWER 2	Time for lowering the docking leveller into the resting position.	1 – 20 sec.	2 sec.
TIME HYDR.	Maximum run-time of the hydraulic power unit. The run-time monitoring of an individual movement serves to avoid an overload with sticking buttons or defective limit switches.	0 – 254 sec.	60 sec.
TRALIGHT MOD	Function of the external traffic lights after the loading process. The loading bridge is back in the standby position (HOME position).  MOD 1: Always switched off. MOD 2: In when in standby position. MOD 3: Out after 5 minutes when in standby position. MOD 4: On in the resting position without end position query for gate. For ramps without gate connection. MOD 5: Off after 5 minutes in the resting position without end position query for gate.	MOD 1 – MOD 5	MOD 3

Function	Description	Adjustment options	Factory setting
HO/FAN/DL	<p>Actuation of warning signal, fan (shelter function) and loading light. The set MOD pertains to the components connected to X4 / 3-7.</p> <p>MOD 1: Horn Produces a warning signal if the wheel block is removed during loading for example.</p> <p>MOD 2: Fan Actuation of a fan for the gate seal during the loading process (shelter function). This MOD sets itself automatically if MOD2 or MOD3 have been selected in the SHELTER parameter.</p> <p>MOD 3: Automatic loading light When lifting for the first time, the light switches on and remains on until the loading bridge is back in the standby position (HOME).</p> <p>MOD 4: Manual loading light The loading light can be manually switched on and off via the LOWER button. A precondition for this is the setting MOD1 in the LOWER parameter.</p>	MOD 1 – MOD 4	MOD 1
AUTO-RETURN	<p>The AUTO-RETURN process describes the automatic resetting of the loading bridge after the loading process in the standby position (HOME). The process is triggered by pressing the AR button (blue).</p> <p>MOD 1: Auto-return function deactivated.</p> <p>MOD 2: Auto-return function activated.</p> <p>MOD 3: Auto-return also via the LIP BACK button. If the button is pressed for longer than 4 seconds, the AUTO-RETURN process also starts.</p> <p>MOD 4: Shortened auto-return cycle without first retraction. → "4.2 Automatic Return (AR)"</p>	MOD 1 – MOD 4	MOD 2
WHEEL BLOCK	<p>MOD 1: Wheel block function deactivated.</p> <p>MOD 2: Wheel block function activated. if the wheel block is removed during the loading process, the traffic lights switch to red and the horn signals this.</p> <p>MOD 3: Wheel block function activated. if the wheel block is removed during the loading process, the keypad is blocked.</p>	MOD 1 – MOD 3	MOD 1

Function	Description	Adjustment options	Factory setting
VEHICLE SEN	<p>Function of the approach sensor (X3/9-10) when driving a vehicle up to the loading bridge.</p> <p>MOD 1: Deactivated.</p> <p>MOD 2: Approach sensor activated. Loading bridge without gate controller connected. Optical and acoustic collision protection through an approach sensor. If a vehicle drives in front of the gate and activates the approach sensor (continuous signal) a warning signal sounds and the red external traffic light switches on and the red internal traffic light flashes. The loading bridge is released for actuation.</p> <p>MOD 3: Approach sensor activated. Loading bridge with gate controller connected. Optical and acoustic collision protection through an approach sensor. If a vehicle drives in front of the gate and activates the approach sensor (continuous signal) a warning signal sounds and the red external traffic light switches on and the red internal traffic light flashes. The gate function is released and it is possible to actuate the loading bridge as soon as the gate is opened.</p> <p>MOD 4: Identical to MOD 2, although the ramp is blocked after the actuation of AR until the next docking instance.</p>	MOD 1 – MOD 4	MOD 1

Function	Description	Adjustment options	Factory setting
SHELTER	<p>Activation of a seal to prevent temperature fluctuations between the truck loading bay and the inside of the building. This can consist of an inflatable seal (fan) or a winding seal (tubular motor). The shelter function is only expedient in conjunction with a power-actuated gate and a gate controller connected.</p> <p>MOD 1: Deactivated.</p> <p>MOD 2: The sealing function is activated via a button command on the free input (X3 / 7-8). The free input is automatically set to MOD4 (SHELTER button). The parameter HU/LI/SH is automatically set to MOD2 (fan). The output for the tubular motor is also active during the shelter time. The gate can now be opened and the loading bridge can be brought into position. Once the loading process has ended, a CLOSE command (X5 / 1-2) is automatically issued to the gate controller. Deactivation of the shelter function takes place when the gate is closed again.</p> <p>MOD 3: Like MOD2, although the deactivation takes place manually via a second button command on the free input.</p> <p>MOD 4: The sealing function is activated via a button command on the free input (X3 / 7-8). Actuation of the fan takes place for the duration of the set shelter time via an external contactor on the tubular motor output. The HU/LI/SH output can now be otherwise used. The gate can now be opened and the loading bridge can be brought into position. Once the loading process has ended, a CLOSE command is automatically issued as a pulse (X5 / 1-2) to the gate controller. Deactivation of the shelter function takes place again via the external contactor for the duration of the shelter time once the gate is closed again.</p> <p>MOD 5: Like MOD 4, although the gate opens automatically after the shelter time has passed. (Prerequisite: Connection X5/1-2 with programmable input 1 of the controller CS3x0 / setting MOD4). Automatic closure of the gate by setting the opening time = 1 sec. (CS3x0).</p> <p>MOD 6: Like MODE 2 except gate release is only issued once the shelter has been inflated.</p>	MOD 1 – MOD 6	MOD 1
SHELTER TIME	<p>Delay time for the release of the gate after activation of the sealing function (SHELTER). After the time has passed, the gate can be opened and loading can start. With deactivation of the sealing function after the loading process, the time starts again and once it has passed the external green traffic light signals that the vehicle can leave the loading bridge.</p>	0 – 254 Sek.	5 Sek.
INTERLOCK POL	<p>Selection of the release contact. The function of the loading bridge can be blocked or released with the aid of a potential-free contact for the gate controller or an external sensor, and can therefore not be moved with a closed door.</p> <p>MOD 1: NC contact MOD 2: NO contact</p>	MOD 1 – MOD 2	MOD 1

Function	Description	Adjustment options	Factory setting
INTERLOCK	<p>Function with a blocking of the loading bridge during the loading process.</p> <p>MOD 1: If the loading bridge release is withdrawn during the loading process, the bridge remains in the floating position, the hydraulic power unit is switched off, the keypad for the loading bridge is deactivated and both traffic lights switch to red. If the signal horn is activated, an acoustic warning signal is issued.</p> <p>MOD 2: If the loading bridge release is withdrawn during the loading process, the bridge remains in the floating position and both traffic lights switch to red. If the signal horn is activated, an acoustic warning signal is issued.</p>	MOD 1 – MOD 2	MOD 1
FREE 1	<p>Function of the freely programmable input (X3/7-8).</p> <p>MOD 1: Deactivated</p> <p>MOD 2: Traffic light acknowledgement. Connection of an acknowledge button with NO contact. The external green traffic light (release of the truck) is only active if the loading bridge is back in the standby position (HOME), the wheel base is removed and the acknowledge button has been actuated. <i>Only in conjunction with an HGV sensor!</i></p> <p>MOD 3: Safety fence with NC contact. If the safety fence is closed, it is not possible to operate the loading bridge.</p> <p>MOD 4: Shelter function. Seal between the truck loading bay and the building interior. Connection of a button with NO contact. If the button is pressed, activation of the sealing function takes place (see SHELTER / SHELTER TIME parameter).</p> <p>MOD 5: LOWER sensor. Connection of a sensor with NO contact. Prerequisite: The LOWER parameter is automatically set to MOD4. The loading bridge only assumes the floating position once the sensor has detected the loading bay of the truck.</p>	MOD 1 – MOD 5	MOD 1
CURRENT CTRL	<p>The value (in %) is the maximum permissible overshooting of the motor current of the hydraulic power unit when arriving in a limit position. With an overshoot, the unit switches off and the loading bridge assumes the floating position. This parameter must be aligned with the respective unit. If the setting is 0%, current monitoring is deactivated.</p>	0 % – 35 %	20 %
TIMEBASE	<p>With this parameter, different speeds of the extendable lip can be set when retracting and extending. A negative value must be selected if the lip is retracted faster.</p>	- 90 % – 100 %	0 %
T HINGE (Only visible if valve mode=3-5)	<p>After the set time, valve 1(Y1) is switched off to extend the hinged lip.</p>	0.1 – 25 sec.	0 sec.
FACTORY MODE	<p>MOD 1: Feed function MOD 2: Hinged lip function</p>	MOD 1 – MOD 2	MOD 1

## 7.3 Function tables for valve actuation

### 7.3.1 Version with feed lip (FACTORY MODE 1)

<b>MODE 1</b> <b>3 valves / Standard / Stertil / Hafa / Rite Hite</b>				
		<b>Stop</b>	<b>Extend lip</b>	<b>Lip back</b>
<b>Function</b>	<b>Contactactor</b>	<b>Y1</b>	<b>Y2</b>	<b>Y3</b>
Raise	1	1	0	0
Lower	0	1	0	0
Extend lip	1	0	1	0
Lip back	1	0	0	1
Floating position	0	1	0	0
Emergency stop	0	0	0	0

<b>MODE 2</b> <b>3 valves / Spezial</b>				
		<b>Stop</b>	<b>Extend lip</b>	<b>Lip back</b>
<b>Function</b>	<b>Contactactor</b>	<b>Y1</b>	<b>Y2</b>	<b>Y3</b>
Raise	1	1	0	0
Lower	0	1	0	0
Extend lip	1	0	1	0
Lip back	1	0	0	1
Floating position	0	1	0	0
Emergency stop	0	0	0	0

<b>MODE 3</b> <b>2 valves / Standard</b>				
		<b>Stop</b>	<b>Lip</b>	
<b>Function</b>	<b>Contactactor</b>	<b>Y1</b>	<b>Y2</b>	
Raise	1	1	0	
Lower	0	1	1	
Extend lip	1	0	0	
Lip back	1	0	1	
Floating position	0	1	1	
Emergency stop	0	0	0	

<b>MODE 4</b> <b>2 valves / HAFA</b>			
<b>Function</b>	<b>Contactora</b>	<b>Y1</b>	<b>Y2</b>
Raise	1	0	1
Lower	0	1	0
Extend lip	1	0	0
Lip back	1	0	1
Floating position	0	1	0
Emergency stop	0	0	0

<b>MODE 5</b> <b>3 valves / Zuccaro</b>				
<b>Function</b>	<b>Contactora</b>	<b>Stop</b>	<b>Extend lip</b>	<b>Lip back</b>
		<b>Y1</b>	<b>Y2</b>	<b>Y3</b>
Raise	1	1	0	0
Lower	0	1	0	0
Extend lip	1	0	1	0
Lip back	1	0	0	1
Floating position	0	1	0	0
Standby position	0	0	0	0
Emergency stop	0	0	0	0

<b>MODE 6</b> <b>3 valves / LAWECO</b>				
<b>Function</b>	<b>Contactora</b>	<b>Stop</b>	<b>Extend lip</b>	<b>Lip back</b>
		<b>Y1</b>	<b>Y2</b>	<b>Y3</b>
Raise	1	1	0	0
Lower	0	1	0	0
Extend lip	1	0	1	0
Lip back	1	0	0	1
Floating position	0	1	0	1
Standby position	0	0	0	0
Emergency stop	0	0	0	0

<b>MODE 7</b> <b>3 valves / COBELUX</b>				
<b>Function</b>	<b>Contactora</b>	<b>Stop</b>	<b>Extend lip</b>	<b>Lip back</b>
		<b>Y1</b>	<b>Y2</b>	<b>Y3</b>
Raise	1	0	0	0
Lower	0	1	0	0
Extend lip	1	0	1	0
Lip back	1	0	0	1
Floating position	0	1	0	0
Standby position	0	1	0	0
Emergency stop	0	0	0	0



<b>MODE 8</b> <b>2 valves / Spezial</b>			
		<b>Stopp</b>	<b>Lip</b>
<b>Function</b>	<b>Contactora</b>	<b>Y1</b>	<b>Y2</b>
Raise	1	1	0
Lower	0	1	1
Extend lip	1	0	1
Lip back	1	0	0
Floating position	0	1	1
Emergency stop	0	0	0

### 7.3.2 Version with hinged lip (FACTORY MODE 2)

<b>MODE 1</b> <b>1 valve / control standard</b>		
		<b>Stop</b>
<b>Function</b>	<b>Contactora</b>	<b>Y1</b>
Raise	1	1
Lower	0	1
Floating position	0	1
Emergency stop	0	0

<b>MODE 2</b> <b>1 valve / control special</b>		
		<b>Stop</b>
<b>Function</b>	<b>Contactora</b>	<b>Y1</b>
Raise	1	0
Lower	0	1
Floating position	0	1
Emergency stop	0	0

<b>MODE 3</b> <b>2 valves / control special</b>			
<b>Function</b>	<b>Contactora</b>	<b>Y1</b>	<b>Y2</b>
Raise	1	1	0
After Y1 time has elapsed	1	0	0
Lower	0	0	1
Floating position	0	0	1
Emergency stop	0	0	0

## 7.4 Diagnostics operating mode



Display	Meaning	Condition
TOP INPUT	Safety circuit (X2 / 1+2)	ON: closed OFF: interrupted (fault)
WHEEL BLOCK	Wheel block (X3 / 1+2)	ON: actuated (vehicle detected) OFF: not actuated
INTERLOCK	Release of the loading bridge through the gate controller (X3 / 3+4)	ON: active (release) OFF: not active (blocked)
HOME LS	Loading bridge limit switch for querying the standby position (X3 / 5+6)	ON: actuated (HOME position) OFF: not actuated
FREE 1	Programmable input (X3 / 7+8)	ON: active OFF: not active
VEHICLE SEN	Loading bridge approach sensor (X3 / 9+10)	ON: actuated (vehicle detected) OFF: not actuated
EXTEND (only feed lip version - FACTORY MODE 1)	EXTEND LIP button (X6 / 2 keypad)	ON: actuated OFF: not actuated
RETRACT (only feed lip version - FACTORY MODE 1)	LIP BACK button (X6 / 3 keypad)	ON: actuated OFF: not actuated
DECK UP	RAISE button (X6 / 4 keypad)	ON: actuated OFF: not actuated
AUTO-RETURN	AUTORETURN (AR) button (X6 / 5 keypad)	ON: actuated OFF: not actuated
DECK DOWN	LOWER button, if available (X6 / 6 keypad)	ON: actuated OFF: not actuated
CYCLE	Loading bridge cycle counter	Display of the cycles that have run through

## 7.5 Fault display on the LCD monitor

Fault / fault message	Cause	Rectification
System does not react.	- No voltage present.	- Check power supply.
Loading bridge does not lift when RAISE button is actuated.	- If no release of the loading bridge is issued by the gate controller or a sensor (X3 / 3+4).	- Check potential-free output of the controller. - Check sensor.
Loading bridge does not lift when RAISE button is actuated and LED 1 is off.	- No clockwise rotating field at the feed.	- Check rotating field and change if necessary (Exchange 2 phases on the mains connection).
Loading bridge does not lift when RAISE button is actuated, LED 1 is on and the hydraulic power unit is running.	- Hydraulic power unit is incorrectly connected.	- Exchange 2 phases on the connection to the hydraulic power unit.
HYERROR RUNTIME	- The programmed maximum run-time of the hydraulic power unit was exceeded.	- Check buttons und cabling. - Measure run-time and readjust if necessary.
ERROR ROTATION	- No clockwise rotating field at the feed.	- Check rotating field and change if necessary (Exchange 2 phases on the mains connection).
EMERGENCY STOP	- The safety circuit (X2 / B1+B2) is interrupted or power failure during an undefined position.	- Check safety circuit. - Press the RAISE button and then the AR button and hold both down (loading bridge returns to the standby position).
INTERLOCK MISS.	- No release of the loading bridge is issued by the gate controller or a sensor (X3 / 3+4).	- Check position of the gate. - Check potential-free output of the controller or sensor.
ERROR	- Switch / sensor for bridge release, approach or wheel block monitoring are not in a permissible state during the loading process. ->(X3 / 3+4 and 9+10)	- Check switch / sensor.

## 7.6 Fault display via LED 1

Fault / fault message	Cause	Rectification
LED off	- No clockwise rotating field at the feed.	- Check rotating field and change if necessary (Exchange 2 phases on the mains connection).

## 8. Care

### WARNING!

#### **Risk of fatal injury due to electric shock!**

Contact with live parts can lead to electric shock, burns and death.

- It is vital that you disconnect the control unit from the power supply before cleaning.
- Take measures to ensure that the power supply remains disconnected for the duration of the cleaning operation.

### ATTENTION!

#### **Danger of damage due to improper handling!**

When cleaning the control unit, never use direct water jets, high pressure cleaners, acids or alkaline solutions.

- Use a soft, non-linting cloth for cleaning.

If particularly dirty, the housing can be cleaned using a mild detergent.

- Clean the outside of the housing using a damp cloth.

## 9. Servicing

### 9.1 Maintenance

The control unit is maintenance-free.

### 9.2 Testing

The control unit must be tested once-yearly.

Testing must be performed by qualified specialist personnel.

→ "1.2.2 Specialist personnel"

### WARNING!

#### **Risk of fatal injury due to electric shock!**

Contact with live parts can lead to electric shock, burns and death.

- Before testing, be sure to disconnect the control unit from the power supply.
- Ensure that the electricity supply remains disconnected during testing.

### ATTENTION!

#### **Danger of damage due to improper testing!**

To avoid damaging the control unit or the dock levellers, the following points must apply:

- Worn or defective parts must be replaced.
  - Only install approved parts.
  - Testing must be documented.
- Check all electrical cables and the housing for any damage. Replace any defective cables immediately.

Replaced defective parts must be disposed of correctly.

## 10. Disassembly

Disassembly by qualified specialist personnel only.

→ "1.2.2 Specialist personnel"

### WARNING!

#### **Risk of fatal injury due to electric shock!**

Contact with live parts can lead to electric shock, burns and death.

- Before disassembly, be sure to disconnect the control unit from the power supply.
- Take measures to ensure that the power supply remains disconnected during dismantling.

## 11. Disposal

Disposal by qualified specialist personnel only.

→ "1.2.2 Specialist personnel"

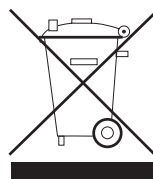

Do not dispose of old equipment or batteries with normal household waste!

- Dispose of old equipment at a collection centre for electronic scrap or via your specialist dealer.
- Dispose of used batteries in a recyclables collection container for used batteries or via your specialist dealer.
- Dispose of the packaging materials in a collection container for paper, cardboard and plastic.

## 12. Declaration of incorporation

within the context of EC Directive 2006/42/EC (Machinery) for integration of an incomplete machine in accordance with Annex II, Part 1B.

### Declaration of conformity

in accordance with the Directive 2014/30/EU (EMC)  
in accordance with the Directive 2011/65/EU (RoHS)

Marantec Legden GmbH & Co.KG,  
Neue Mühle 4,  
D - 48739 Legden

We hereby declare that the following listed product

Product designation: **Control unit for dock levellers**  
Type designation: **RS 301 K, RS 301 V**

is exclusively intended for installation in a dock leveller system and has been developed, constructed, and manufactured in harmony with the following directives:

Machinery Directive 2006/42/EC

Annex 1: 1.1.2, 1.1.3, 1.1.5, 1.2.1, 1.2.2, 1.2.3, 1.2.4.2, 1.2.5, 1.2.6, 1.3.1, 1.3.2, 1.3.3, 1.3.4, 1.3.9, 1.5.1, 1.5.2, 1.5.4, 1.5.5, 1.5.6, 1.5.7, 1.5.8, 1.5.9, 1.5.10, 1.5.11, 1.5.13, 1.6.1, 1.6.2, 1.6.3, 1.6.4, 1.7.1.1, 1.7.1.2, 1.7.2, 1.7.3, 1.7.4.3.

EMC Directive 2014/30/EU - Electromagnetic Compatibility  
RoHS Directive 2011/65/EU - Hazardous substances in electrical and electronic equipment  
LVD Directive 2014/35/EU - Low voltage in accordance with Annex I part 1.5.1 of 2006/42/EC

Applied and referenced standards:

EN 1398:2009	Dock levellers - Safety requirements
EN 60204-1:2019	Safety of machinery - Electrical equipment of machinery - Part 1: General requirements
EN IEC 61000-6-2:2019	Electromagnetic Compatibility (EMC) - Part 6-2: Generic standards - Immunity standard for industrial environments
EN IEC 61000-6-3:2022	Electromagnetic Compatibility (EMC) - Part 6-3: Generic standards - Emitted interference from equipment in living areas
EN IEC 61000-6-4:2020	Electromagnetic Compatibility (EMC) - Part 6-4: Generic standards - Emission for industrial environments

The special technical documentation has been prepared in accordance with Annex VII Part B of the Machinery Directive (2006/42/EC).

We undertake to transmit these to the market surveillance authorities in electronic form within a reasonable period of time upon justified request.

The authorised representative for the compilation of the technical documentation is the undersigned.

Incomplete machines within the scope of Directive 2006/42/EC are only specified for integration with other machines or other incomplete machines or plants or connection with them to form a machine together with them within the context of the Directive indicated above. For this reason, this product may only be commissioned if it has been confirmed that the complete machine/system that it has been integrated with complies with the requirements of the above EC directives.

This declaration is void if changes are made to the product without our approval.

Legden, 01.08.2022



Dirk Wesseling, Managing Director



## Declaration of incorporation

within the context of Supply of Machinery (Safety) Regulations 2008 for incorporation in a an incomplete machine according to Appendix II, Part 1B

Marantec Legden GmbH & Co.KG  
Neue Mühle 4  
D-48739 Legden

## Declaration of conformity

within the context of Electromagnetic Compatibility Regulations 2016 within the context of The Restriction of the Use of Certain Hazardous Substances in Electrical and Electronic Equipment Regulations 2012

**UK Representative:**  
Link Controls  
Stuart Road, Manor Park  
Runcorn Cheshire, WA7 1TS

We hereby declare that the following listed product

Product designation: **Controls for dock levellers**

Type designation: **RS301 K, RS301 V**

is exclusively intended for integration in a dock leveller system and has been developed, designed and produced in accordance with the following Directives:

Supply of Machinery (Safety) Regulations (2008 No.1597)

Appendix 1: 1.1.2, 1.1.3, 1.1.5, 1.2.1, 1.2.2, 1.2.3, 1.2.4.2, 1.2.5, 1.2.6, 1.3.1, 1.3.2, 1.3.3, 1.3.4, 1.3.9, 1.5.1, 1.5.2, 1.5.4, 1.5.5, 1.5.6, 1.5.7, 1.5.8, 1.5.9, 1.5.10, 1.5.11, 1.5.13, 1.6.1, 1.6.2, 1.6.3, 1.6.4, 1.7.1.1, 1.7.1.2, 1.7.2, 1.7.3, 1.7.4.3.

Electromagnetic Compatibility Regulations (2016 No.1091)

The Restriction of the Use of Certain Hazardous Substances in Electrical and

Electronic Equipment Regulations (2012 No.3032)

Electrical Equipment (Safety) Regulations (2016 No.1101) according to Annex I Part 1.5.1 of "2008 No.1597"

Applied and consulted standards:

EN 1398:2009	Dock levellers - Safety requirements
EN 60204-1:2019	Safety of machinery - Electrical equipment of machines - Part 1: General requirements
EN IEC 61000-6-2:2019	Electromagnetic compatibility (EMC) - Part 6-2: Generic standards - Immunity standard for industrial environments
EN IEC 61000-6-4:2020	Electromagnetic compatibility (EMC) - Part 6-4: Generic standards - Emission standard for industrial environments

The special technical documents were created according to Appendix VII Part B of Supply of Machinery (Safety) Regulations (2008 No.1597). We are obligated to transmit these to market monitoring agencies in a timely manner upon justified request in electronic form.

Authorised representative for compiling the technical documents is the undersigned.

Incomplete machines within the context of Supply of Machinery (Safety) Regulations 2008 are therefore only specified for incorporation with other machines or with other incomplete machines or systems or combined with them to form a machine within the contact of the directive indicated above. For this reason, this product may only be commissioned once it has been determined that the complete machine /system into which it has been incorporated corresponds with the indicated UK guidelines.

In case of changes to the product that are not confirmed by us, this declaration is void.

Legden, dated 01.11.2022



Dirk Wesseling, General Manager









**Terminal strip X3**  
(Approach sensor)

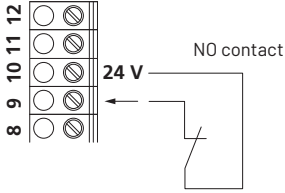

**Terminal strip X3**  
(Wheel block)

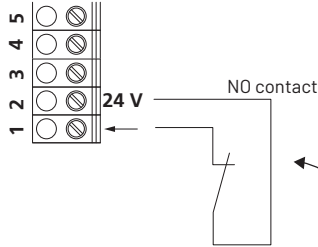

**Terminal strip X3**  
(Bridge release  
from the gate controller or sensor)

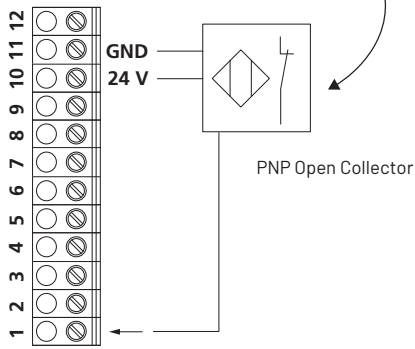
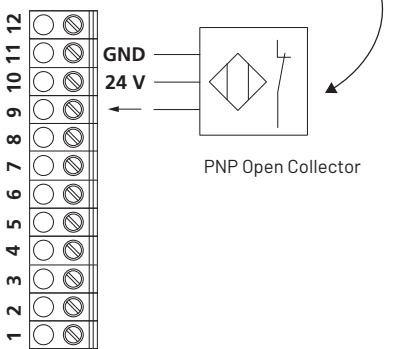
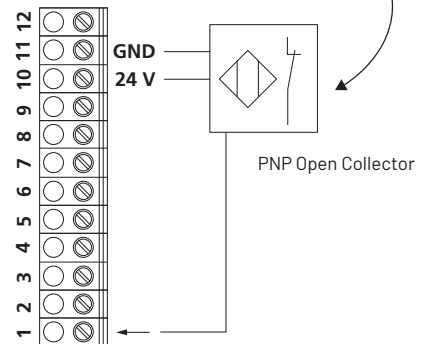
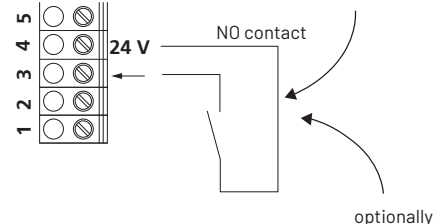
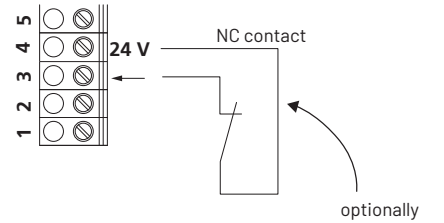

**Terminal strip X3**  
(Limit switch bridge / free input)

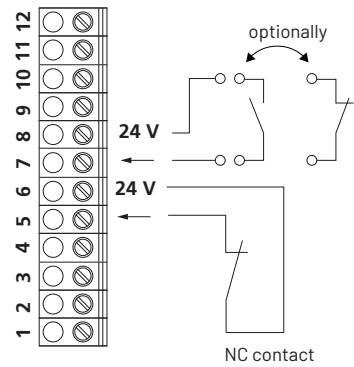

**Terminal strip X2**  
(Unit / emergency stop)

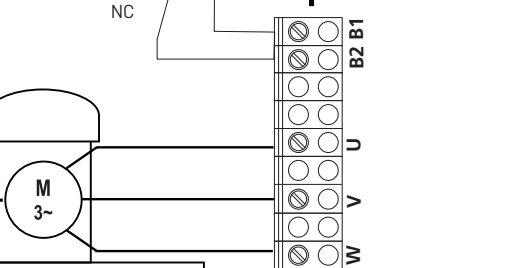

**Terminal strip X1 / PE**  
(Power supply)

