

Operation Instructions RS200L

EN



EN 1 Contents

1	Contents	2
2	Key to symbols	2
3	General safety instructions	2
4	Overview of products	3
5	Initial Operation - General instructions	5
6	Initial Operation	5
7	Protection against uncontrolled movements	6
8	Overload protection	7
9	Error messages and rectification	7
10	Technical data	7

2 Key to symbols



Danger of personal injury!

The safety instructions must be observed!



Warning! Danger to property!

The safety instructions must be observed!



Information

Special information OR

Reference to other sources of information

3 General safety instructions

Guarantee

The function and safety of the equipment is only guaranteed if the warning and safety instructions included in these operating instructions are adhered to.

MFZ Antriebe GmbH & Co. KG is not liable for any personal injury or damage to property that occurs as a result of the warning and safety instructions being disregarded.

Using the equipment for its intended purpose

The RS200L controls are designed only for dock levellers with hinged lip.

Target group

Only qualified and trained electricians may connect, program and service the controls.

Qualified and trained electricians meet the following requirements:

- knowledge of the general and specific safety and accident prevention regulations,
- knowledge of the relevant electrical regulations,
- trained in the use and care of appropriate safety equipment,
- capable of recognising the dangers associated with electricity.

Instructions for installation and connection

- The controls must be disconnected from the electricity supply before carrying out electrical works. It must be ensured that the electricity supply remains disconnected during the works.
- Local protective regulations must be complied with.



Key

A: Button leveller up

B: mains switch

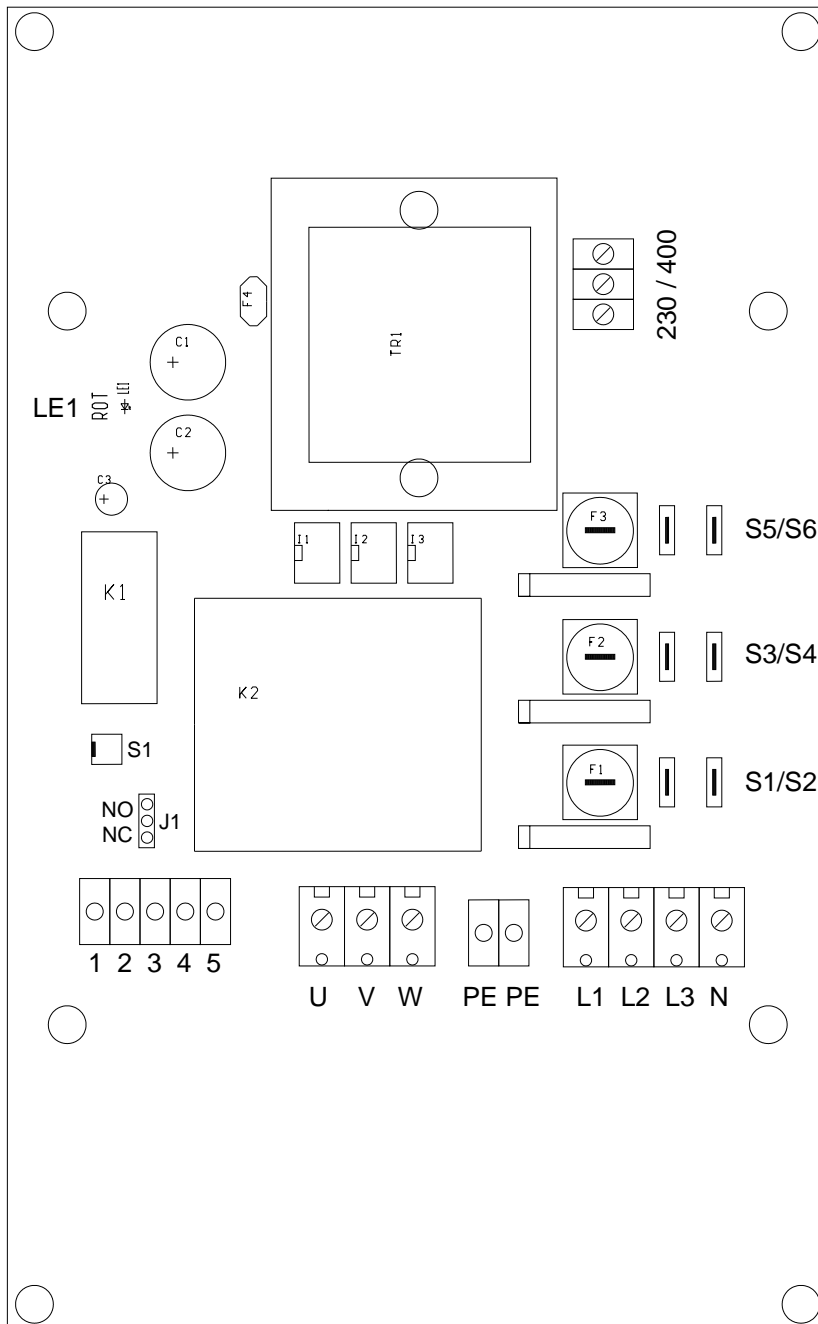
Key:

L1, L2, L3, N, PE:
terminal block
mains connection

S1 ... S6:
connection mains switch

U, V, W, PE: terminal block
hydraulic unit

3, 4, 5: terminal block interlock
door - leveller

1,2: terminal block valve

S1: socket for push button
leveller up

230/400: terminal block
adjustment of mains voltage

K1: Relay valve

K2: Contactor
hydraulic unit

F1-F3: overload protection

F4: Resettable PTC

TR1: Transformer

5 Initial Operation – general instructions



Warning!

To guarantee that the equipment functions properly, the following points must be ensured:

- The dock leveller is installed and operational.
- The command and safety devices are installed and ready for operation.
- The control housing with the RS200 is installed..



Information:

For the installation of the dock leveller, the hydraulic unit and the command and safety devices, the relevant manufacturer's instructions are to be adhered to.

Mains connection



Danger!

To guarantee that the controls function properly, the following points must be ensured:

- The mains voltage must correspond to the voltage stated on the type plate.
- For a three-phase current, a clockwise rotating field is required.
- For a three-phase connection, only 3-way automatic circuit breakers (10A) may be used.



Warning!

Before switching on the controls for the first time, a check must be carried out after completing the wiring to ensure that all the motor connections at the motor and at the controls are securely fixed. All control voltage inputs are galvanically isolated from the supply.

6 Initial Operation

Mains voltage adjustment



A wrong adjustment of the mains voltage can destroy the control.

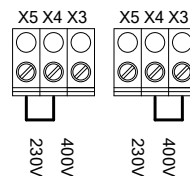

Factory setting 400V

Mains supply

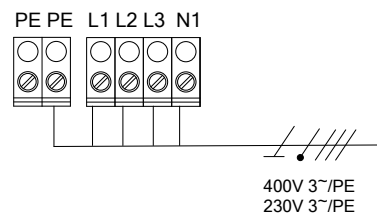

Mains switch

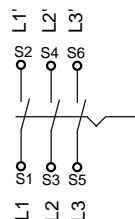

Connection dock leveller

U, V, W, PE: hydraulic unit

For a three-phase current, a clockwise rotating field is required.

1/2: Y1 valve

push button leveller up

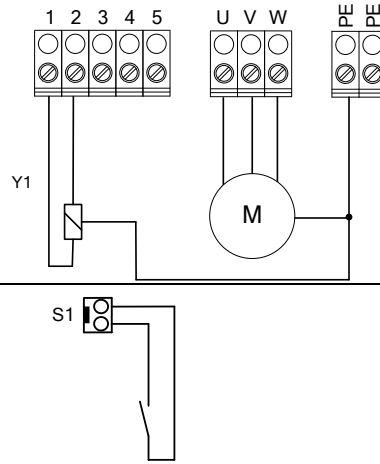

interlock door – leveller:
potential-free switch

NO or NC switches can be used alternatively. If the jumper J1 is in position J1=NC and no switch is connected, the input must be bridged (+ to IN).

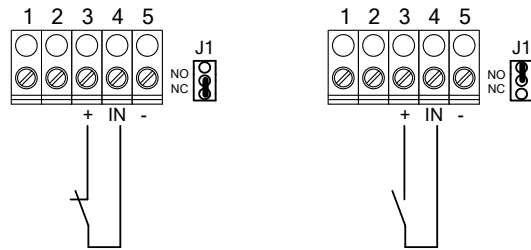

interlock door – leveller:
Sensor PNP open collector

NO or NC sensors can be used alternatively. If the jumper J1 is in position J1=NC and no sensor is connected, the input must be bridged (+ to IN).

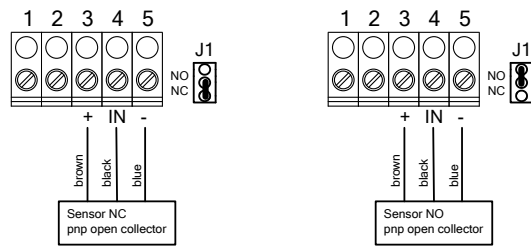

7. Protection against uncontrolled movements

EN

The control RS200L possesses an integrated protection circuit against uncontrolled movements. It is activated if during normal operation an emergency stop signal is given to the dock leveller or if voltage supply is interrupted. After release of the emergency stop or power up, the dock leveller the valve stay closed, until the push button leveller up button is activated.

8. Overload protection

The control RS200L possesses an integrated overload circuit for the hydraulic unit. Each phase is examined for overload. As soon as this is the case, the contactor switches automatically off. Further the circuit is secured against phase failure. Both errors are signalled by the red LED LE1.

9. Error messages and rectification / LED

Error messages	Cause	Rectification
System does not respond	No mains power	Check mains power to control box
Leveller is not raising when the UP button is operated.	interlock door – leveller is activated	Check interlock contact
Leveller is not raising when the UP button is operated, although motor is running	Field rotation is wrong	Swap two phase wires of the hydraulic unit
Red LED ON	Overload protection is activated	Check hydraulic unit, cabling and fuses

10 Technical Data

Mains supply	3~ 400VAC, 50 Hz, +/- 10% 3~ 230VAC, 50 Hz, +/- 10%
Fuse supply voltage F1-F3	3 x 3,15A T at 400VAC 3 x 5A T at 230 VAC
Mains fuses	10A K- characteristic
Control voltage	24 VDC max. 0,9 A
Fuse control voltage (F4)	Resettable fuse 1,6 A
Maximal loads Hydraulic unit	Max 2,2 KW 6 A
Valve	24 VDC +/- 10%, 0,6 A / 100%
Mounting	Vertical on the wall , min. height 100 cm
Housing dimensions	215 mm x 275 m x 190 mm
Ambient temperature	-10° C ... +55°C
Storage temperature	-20°C ... +85°C
Isolation class	IP 65
Weight	5,5 Kg

